

STEP Robot Maintenance Manual

Product Name: SA6/1440H

Publication Status: Standard

Product version: V2.2

Shanghai STEP Robotics Co., Ltd. of China is solely responsible for the preparation and printing of the user operation and programming guide of this control system.

Copyright. All rights reserved.

Without the permission of Shanghai Step Robotics Co., Ltd., no organization or individual may excerpt or copy all or part of this book (software, etc.) without authorization, and may not disseminate it in any form (including materials and publications).

All rights reserved. Any infringement will be prosecuted. The content is subject to change without prior notice.

All Copyright© reserved by Shanghai STEP Robotics Co., Ltd., China.

PREFACE

Before using the robot, be sure to read the STEP robot user manual carefully and operate the robot based on your understanding of the contents.

Key points

This user manual systematically explains the installation, use, function parameter setting, and maintenance of the SA6/1440H robot. This manual can be used as a reference for system integrators to design user workstation systems using our company's SA6/1440H robot, and can also be used as a reference for system installation, debugging, and maintenance.

To ensure the correct installation and use of the SA6/1440H robot, please read this instruction manual carefully before use.

Reading object

System Integrator
On-site technical support staff
Equipment maintenance personnel
After-sales service staff

Contents

The contents of this manual may be supplemented and modified. Please pay attention to our company's website and update the manual regularly.

Our company's official website: www.stepelectric.com.

Main Features

- a) Small size;
- b) Large working space;
- c) Lightweight;
- d) Fast operation speed;
- e) High repeatability and positioning accuracy;
- f) Strong welding stability.

Safety marking

This instruction manual contains relevant precautions to ensure the personal safety of the operator and prevent damage to the robot system, and is described as "Danger", "Caution", and "Important" according to their importance in safety. Before operating the robot, the user must be familiar with these markings and strictly abide by them.

Improper use may cause dangerous situations that may result in personal injury or death.

Improper use may cause danger and may result in minor or serious personal injury and equipment damage.

The parts that users need to comply with and pay special attention to.

TABLE OF CONTENTS

CHAPTER 1 INSTRUCTIONS FOR USE 1

 1.1 Scope of application..... 1

 1.2 Security Overview 1

 1.3 Unpacking and Inspection 2

 1.4 Usage Environment 3

CHAPTER 2 CARE AND MAINTENANCE 4

 2.1 Maintenance plan 4

 2.1.1 Maintenance Level 4

 2.1.2 Maintenance activities and time 4

 2.1.3 Specific maintenance details 5

 2.2 Main spare parts list..... 7

 2.3 Battery 8

 2.3.1 Battery usage precautions 8

 2.3.2 Replacement of battery 8

 2.4 Lubrication 11

 2.4.1 Grease drain hole locations for each axis 11

 2.4.2 Grease replacement 12

 2.4.3 Regular pressure relief operation 13

 2.5 Synchronous belt 13

 2.5.1 Robot uses synchronous belt model 14

 2.5.2 Precautions for using synchronous belts 14

 2.5.3 Notes on replacing the synchronous belt 14

 2.6 Dismantling and scrapping 15

 2.6.1 Precautions for robot scrapping 16

 2.6.2 Precautions for motor removal and scrapping 16

 2.6.3 Battery removal and disposal precautions 16

SCHEDULE 17

TECHNICAL SUPPORT..... 19

Version Revision Notes

| Version Number | describe | time | Revised by |
|----------------|----------------------------------------------------------------------------------|------------|------------|
| V1.0 | Added | 2024.05.06 | LY |
| V2.1 | Full text revision | 2024/11/13 | LY |
| V2.2 | Overall optimization (Chinese characters on the picture are replaced by letters) | 2025.04.12 | LY |

Chapter 1 Instructions for Use

1.1 Scope of application

It is mainly used in arc welding, handling, stacking, packaging, assembly, grinding and polishing, etc., which completely or partially replace manual work.

1.2 Security Overview



- ◎ Electrical or mechanical debugging and maintenance of industrial robots are only allowed to be performed by professional personnel, and all personnel working on the robots must receive training on the use of the robots.
- ◎ Incorrect installation (e.g. overloading) or mechanical damage (e.g. brake failure) can cause the robot or external axes to sink. If work is to be done on a switched-off robot system, the robot and external axes must first be moved to a state where they cannot move on their own, whether under load or without load. If this is not possible, the robot and external axes must be secured accordingly.
- ◎ During maintenance, especially after replacing the motor, driver, or battery, the robot must be reset to zero before it can automatically run the program, otherwise accidents may occur.



- ◎ Please pay attention to the axis of rotation of the robot body. Keep a distance from the axis to prevent hair or clothing from being entangled. Also, be careful of any dangers that may be caused by rotating tools or other devices installed on the robot or in the cell.
- ◎ Do not, under any circumstances, stand underneath any axis of the robot!
- ◎ Electrical or mechanical debugging and maintenance of industrial robots are only allowed to be performed by professional personnel, and all personnel working on the robot must read and understand the instructions for the robot system safety content.
- ◎ If you are disassembling the control system immediately after it stops running due to power failure, you must wear protective gloves to avoid burns caused by excessive temperature on the radiator surface or motor.
- ◎ When replacing the battery, be careful to avoid short circuiting the positive and negative poles of the battery.



重要

- ◎ Maintenance and servicing must be performed in accordance with the operating instructions, and relevant instructions must be read carefully before operation. This process is generally performed by professionals.
- ◎ The emergency stop button is a safety device used in emergency situations. It is strictly prohibited to use it frequently and without purpose, which will affect the service life of robot-related components (motor brake, etc.). In particular, it is prohibited to arbitrarily and repeatedly turn off the emergency stop button during high-speed operation of the robot.
- ◎ During maintenance, the access switch may be temporarily short-circuited, but it is strictly forbidden to work on live parts of the control system at this time to avoid accidents.

1.3 Unpacking and Inspection



注意

- ◎ Visually inspect the robot to ensure that it is not damaged. Do not install a damaged robot or one that is missing parts, otherwise there is a risk of major accidents and personal injury.
- ◎ Before moving the robot, please check the stability of the robot to avoid the danger of tilting.
- ◎ Cable packaging is susceptible to mechanical damage. Cable packaging must be handled with care, especially connectors, to avoid damaging the cable packaging.
Otherwise the robot cannot operate normally.

When unpacking, please carefully check whether there is any damage during transportation; whether the model and specifications on the nameplate of the machine are consistent with the order requirements. If you find that the model does not match or components are missing, please contact the manufacturer or supplier as soon as possible.

Unpacking list:

1. Robot body;
2. Control cabinet;
3. Teaching pendant;
4. Interdisk line;
5. USB flash drive.

1.4 Usage Environment



© When the robot works in an abnormal environment, it may cause equipment damage.

The robot's working environment is ~45°C and without direct sunlight.

The robot can be used normally in an environment of 10°C~45°C; in an environment of 0°C~10°C, the robot needs to be preheated (run at a low speed for more than 5 minutes) before it can be used normally. It is not recommended to use the robot in an environment below 0°C and above 45°C; otherwise, the equipment may be damaged.

Chapter 2 Care and Maintenance

2.1 Maintenance plan

Notes during maintenance:

Notes during maintenance:

- 1) Do not, under any circumstances, stand under any axis of the robot.
- 2) When cleaning and maintaining the robot, stop the robot's operation and ensure that the power supply, air pressure source, and hydraulic source connected to the robot are disconnected.
- 3) The robot can be cleaned and maintained only after it has cooled to room temperature.
- 4) If cleaning or maintenance operations are to be performed immediately after the control system is powered off and stopped, protective gloves must be worn to avoid burns caused by excessive temperature on the radiator surface or motor.
- 5) When the operator needs to enter the robot safety fence for cleaning, maintenance and other operations due to unavoidable circumstances, he should pay attention to carefully observe the situation inside the safety fence, confirm that there is no danger before entering, and run the robot at a low speed, making sure that the emergency stop button can be pressed at any time.
- 6) Before lifting heavy parts, please check the stability of the lifting equipment and lifting parts to avoid the danger of tilting.

2.1.1 Maintenance Level

There are three levels of robot maintenance. Customers are advised to choose maintenance based on the usage conditions of the purchased robot:

Class A: Replace grease, waveform detection, iron powder concentration detection, robot body cable replacement, robot body and control cabinet battery replacement, etc. Through the above operations, data is obtained to form a robot physical examination report, and the robot is pre-judged before failure, reducing the blindness of spare parts storage.

Level B: Replace grease, detect iron powder concentration, etc. This maintenance can extend the service life of the robot and monitor the wear of the robot's reducer.

Level C: The most basic maintenance, mainly for the purpose of replacing the grease inside the robot reducer, which can extend the service life of the robot reducer.

2.1.2 Maintenance activities and time

The robot also needs regular maintenance to ensure that it functions properly. Table 2-1 specifies some major maintenance activities and time intervals. For specific daily maintenance, please refer to the inspection table in the appendix at the end of this article:

Table 2-1 Robot maintenance list

| Maintenance Activities | equipment | Time interval | Remark |
|------------------------|------------------------------------|----------------------------------------------------------------------------------------------------------------|-----------------------------|
| examine | Robot pipeline | 3 months | Is it worn? |
| examine | Information Labels (Warning Signs) | 1 year | Is it damaged or lost? |
| examine | Hard limit and buffer block | 1 year | Is it bent or damaged? |
| examine | Synchronous belt and pulley | 10000 hours | Check belt tension and wear |
| replace | grease | 11,520 cumulative hours of use or 3 years after the robot was shipped from the factory (whichever comes first) | |
| replace | Encoder battery | 3 years | |

2.1.3 Specific maintenance details

1. Check whether the cable protective cover is damaged (wear, burnt by high temperature in harsh environment, metal cut)



Figure 2.1 Main cable protection inspection

2. Check the motor connector and heavy-duty connector for water stains



Figure 2.2 Check the motor connector



Figure 2.3 Body heavy load connector inspection

3. Check whether the J4, J5, and J6 synchronous pulley belts are worn.

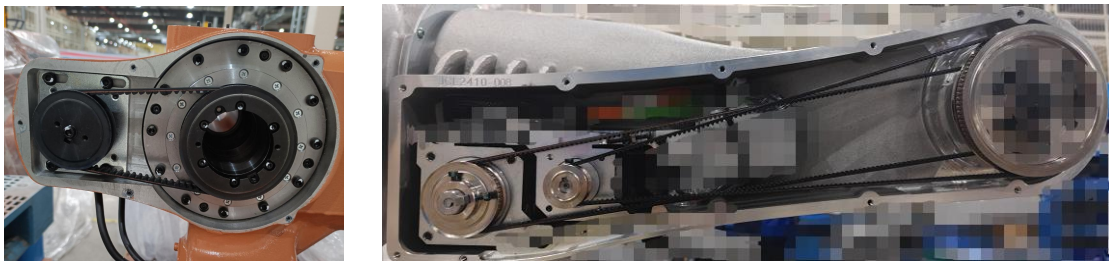

Figure 2.4 J4, J5, J6 synchronous pulley belt inspection

4. Check the wrist and joint axes of the machine to see if there is any oil leakage or abnormal wear caused by cutting or splashing.

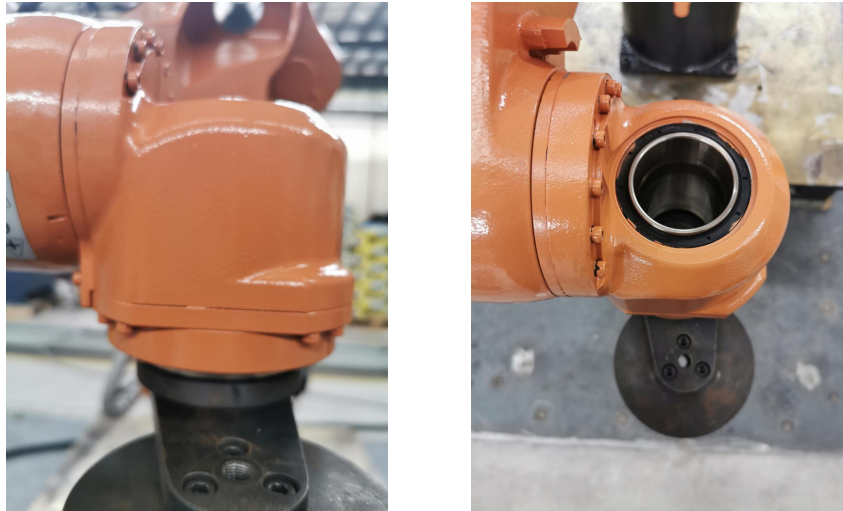

Figure 2.5 Inspection of the wrist part of the body



Figure 2.6 Body joint inspection

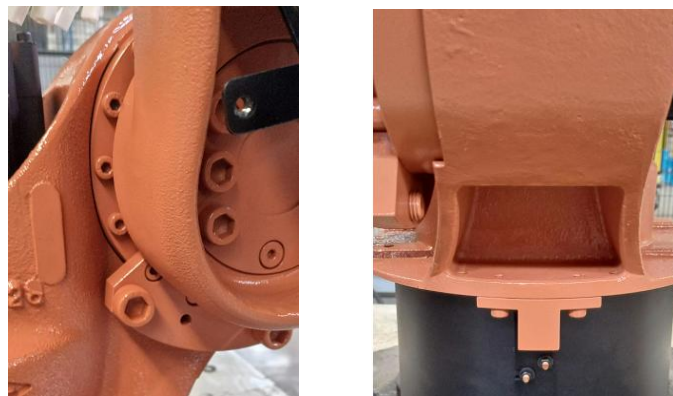

Figure 2.7 Body limit block inspection

2.2 Main spare parts list

The company has sufficient spare parts to fully meet customer needs. Table 2-2 lists the spare parts for the SA6/1440H robot.

Table 2-2 SA6/1440H spare parts list

| Spare part number | name | Material Number | Number of equipment | Quantity per unit | Remark |
|-------------------|---------------------------------|-----------------|---------------------|-------------------|--------|
| 1 | Battery pack (2 pieces per set) | R14120377 | 1 | 1 | |
| 2 | Four-axis synchronous belt | RA0000153 | 1 | 1 | |
| 3 | Five-axis synchronous belt | RA0000152 | 1 | 1 | |
| 4 | Six-axis synchronous belt | R10400238 | 1 | 1 | |
| 5 | 1/2-axis servo motor | RH0001346 | 2 | 2 | |
| 6 | 3-axis servo motor | FK0000150 | 1 | 1 | |
| 7 | 4-axis servo motor | FK0000149 | 1 | 1 | |
| 8 | 5-axis servo motor | FK0000148 | 1 | 1 | |
| 9 | 6-axis servo motor | FK0000147 | 1 | 1 | |

In addition, when purchasing cables and other wires for use in machines, please inform us of the product's manufacturing number in advance; we cannot guarantee the performance of parts used that are not recommended by us.

2.3 Battery

Under normal use conditions, as long as the battery maintains its integrity and its seal is intact, the electrode materials and liquid electrolyte in the battery will not be exposed to the outside world.

The risk of explosion is only present in cases of abuse (mechanical, thermal, electrical), which would result in the activation of the safety valve or the bursting of the battery container. There is also the possibility of electrolyte leakage, reaction of the electrode material with moisture, leading to battery leakage, explosion, fire.

2.3.1 Battery usage precautions

1. Do not short-circuit, charge, puncture, incinerate, crush, soak, forcibly discharge, or expose to temperatures exceeding the specified operating temperature range of the product, as these may cause fire or explosion hazards.
2. Please wear safety glasses when handling batteries.
3. When handling a leak, please wear gloves and chemical protective clothing.
4. When dealing with fire situations, please use a self-contained breathing apparatus.

2.3.2 Replace the battery

When replacing batteries, you must notify STEP's technicians in advance. Replacement can only be carried out after obtaining STEP's written permission. Otherwise, the company will not be responsible for any losses and downtime caused by this.

When replacing batteries, you must notify STEP's technicians in advance. Replacement can only be carried out after obtaining STEP's written permission. Otherwise, the company will not be responsible for any losses and downtime caused by this.

Tools required for battery replacement: diagonal pliers, hexagonal wrench, multimeter, cable tie.

1. Prepare two new batteries in advance. The battery, cable and terminal are integrated into one. The material number is R14120377, as shown below:

: The two cables of the battery connector are black on the left and red on the right. If you do not install them correctly, please do not install them and contact STEP immediately.

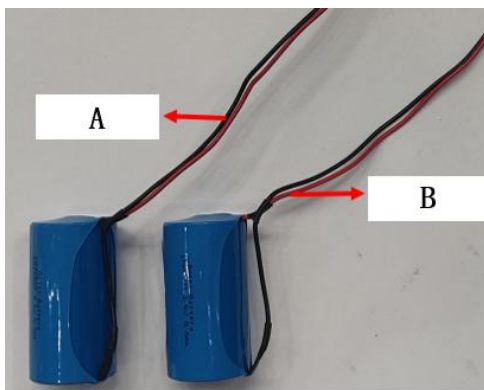

| | |
|---|------------------------|
| A | Black line on the left |
| B | Red line on the right |

Figure 2.8 Battery

2. Use an Allen wrench to remove the side panels of the robot base.

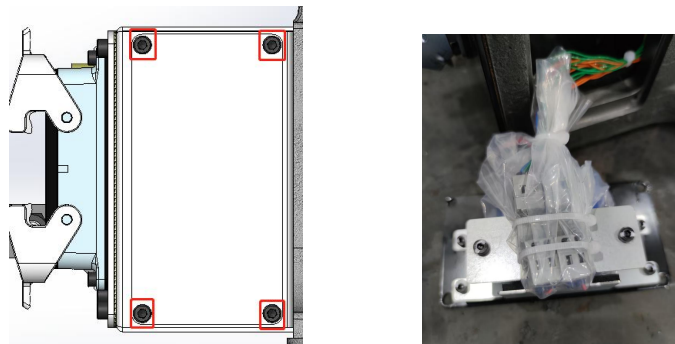

Figure 2.9 Robot base side panel

3. Use diagonal pliers to cut off the cable tie and remove the two fixing screws;



Figure 2.10 Schematic diagram of the positions of the two fixing screws

4. At this time, unplug the connector of one battery, as shown in the figure below.

: Only one connector can be unplugged at a time. If both connectors are unplugged at the same time, the robot will lose its zero point!



Figure 2.11 Plug-in terminals

5. After installing the new battery, unplug the other battery connector.

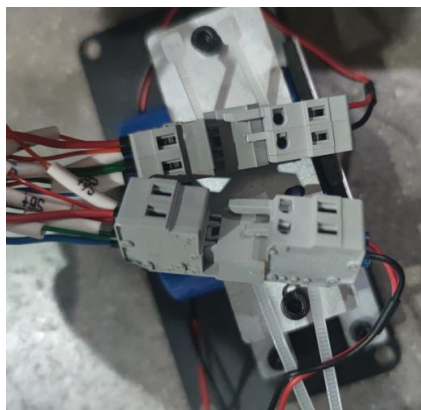

Figure 2.12 Replacing the battery connector

6. After installing the second battery, tighten the fixing screws on the fixing iron sheet and secure the terminals with cable ties.



Figure 2.13 Cable tie fixing diagram

7. After installation is completed, you need to use a multimeter to check whether the voltage at both ends of the terminals is 3.6V. If the voltage value is incorrect, you need to replace the battery.



Figure 2.14 Multimeter detection

8. After the battery is installed, install the base side panel back to its original position.

2.4 Lubrication

In order to give full play to the performance of the robot, please lubricate the machine according to the given grease type. Do not use other brands of grease or mix them with other brands of grease.

2.4.1 Grease hole locations on each axis

The location of the grease holes on each axis of SA6/1440H and the oil filling requirements are shown in Figure 2.15;

| | |
|---|---------------------------|
| A | J2 axis oil drain port |
| B | J1 axis oil drain port |
| C | J1 shaft oil filling port |
| D | J2 axis oil filling port |

| | |
|---|---------------------------|
| E | J3 shaft oil drain port |
| F | J3 shaft oil filling port |
| G | J5 axis oil filling port |

Figure 2.15 Location of grease holes and oil filling requirements for each axis of SA6/1440H

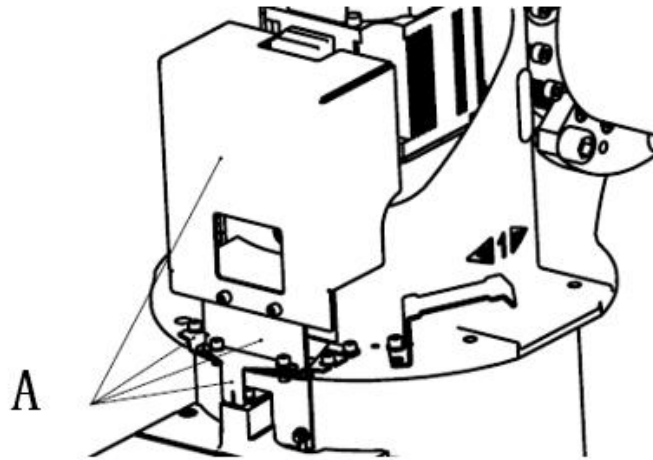

| | |
|---|-----------------------------------------------------------------------------------------------------|
| A | When filling oil on the J1 axis, the sheet metal parts near the oil filling port need to be removed |
|---|-----------------------------------------------------------------------------------------------------|

Figure 2.16

Table 2-3 Location of grease holes and oil filling requirements for each axis of SA6/1440H

| Serial number | Location | Oil quantity | Lubricant name |
|---------------|--------------|--------------|-------------------------------------|
| 1 | J1 reducer | 278±5g | RV reducer special lubricant |
| 2 | J2 reducer | 390±5g | RV reducer special lubricant |
| 3 | J3 reducer | 304±5g | RV reducer special lubricant |
| 5 | J5/J6 cavity | 130g | Special grease for harmonic reducer |

Note: 1. The J5/J6 cavity includes the J5 harmonic reducer cavity;

2. When filling oil into the J1 axis, the sheet metal parts near the oil filling port need to be removed, see Figure 2.16.

2.4.2 Grease replacement

1. Grease is already injected into each axis of the robot before leaving the factory. Use a grease gun to fill the grease when replacing.

2. Based on the aging of the grease, please replace the robot grease 3 years from the date of shipment or 11,520 hours in total, whichever comes first.

Notice:

When the surface temperature of the reducer reaches 40°C or above, or when the joints are continuously operated at a small angle and high frequency, please check the aging and contamination of the grease and shorten the grease replacement cycle to 4000 hours.

3. The amount of grease added should reach about 80% of the oil cavity of the component. For specific details, please consult STEP's after-sales service personnel.

2.4.3 Regular pressure relief operation

For equipment that works for more than 12 hours a day, the J1~J3 axis reducers should be depressurized regularly (recommended every three months). The operation method is as follows: after the machine is warmed up, the robot returns to the zero position, then the equipment is stopped, and the oil plugs at the exhaust ports of each joint are unscrewed. After exhausting, the oil plugs and sealing gaskets are reinstalled and tightened. The entire operation process should take less than 15 minutes.

When unscrewing the oil plug, first slowly loosen it two turns and stop for 1 to 2 minutes to allow the high-pressure gas or grease to be initially discharged; then observe the exhaust situation and slowly remove the oil plug.

Be sure to take care to prevent hot oil from splashing and scalding the operator.

The locations of the exhaust ports at each joint are shown in Figure 2.17.

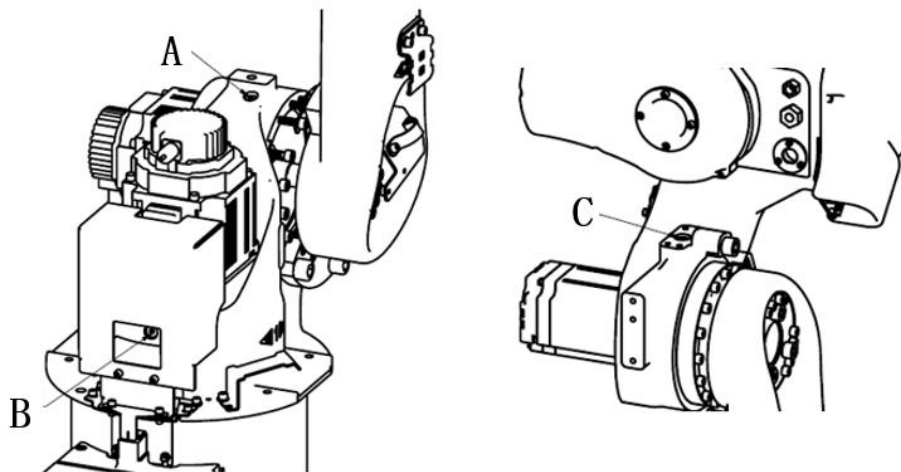

| | |
|---|--------------------|
| A | J2 axis oil outlet |
| B | J1 axis oil outlet |
| C | J3 axis oil outlet |

Figure 2.17 Schematic diagram of the exhaust port locations of each joint

When using the equipment at an altitude higher than 1000 meters, be sure to open the exhaust ports of the above axes before use to balance the pressure difference inside and outside the reducer cavity to prevent the initial pressure difference between the inside and outside from being too large, causing oil leakage in the joints.

2.5 Timing belt

The correct and reasonable use of synchronous belts can not only ensure the smooth progress of production transmission, but also reduce the failure rate of the equipment and extend the service life of the synchronous belts.

2.5.1 Synchronous belt models used by robots

The SA6/1440H robot drive housing assembly and wrist joint transmission use synchronous belts. The synchronous belts are used for transmission between the J4 motor and the J4 reducer, between the J5 motor and the J5 reducer, and between the J6 motor and the J6 bevel gear. The synchronous belts are imported brands with high precision. If replacement is really necessary, please consult the after-sales service personnel of STEP.

2.5.2 Precautions for using synchronous belts

1. Bending is strictly prohibited to avoid damaging the frame material and affecting the belt strength.
2. It is strictly forbidden to scratch the belt to avoid early damage to the belt.
3. Avoid contact with chemicals (especially strong oxidizing acids such as concentrated sulfuric acid).
4. Try to avoid long-term contact with oil and water.
5. Since the tension of the synchronous belt will change with the extension of working time, the operator needs to regularly adjust the tension of the synchronous belt, check the running condition of the synchronous belt and synchronous pulley, and adjust or replace them in time. Refer to Table 2-1 and the attached table for the recommended inspection and maintenance cycle.

2.5.3 Precautions for replacing synchronous belt

1. When replacing the synchronous belt, you must notify the technicians of STEP in advance. Replacement can only be carried out after obtaining written permission from STEP. Otherwise, the company will not be responsible for any losses and downtime caused by this.

2. When purchasing a synchronous belt, choose one with a clean surface, no distortion or deformation, and full teeth.

3. The synchronous belt structure at the drive housing assembly and wrist of the SA6/1440H robot is shown in Figure 2.18 and Figure 2.19. When replacing the synchronous belt, the tension of the belt must be reduced to the minimum before it can be removed. It is strictly forbidden to pry off the synchronous belt with non-professional tools when it is under high tension.

4. When installing the synchronous belt, if the center distance between the two pulleys can be moved, you must first shorten the center distance of the pulleys, and then reset the center distance after installing the synchronous belt. If there is a tensioner, first loosen the tensioner, then install the synchronous belt, and then install the tensioner.

5. The pre-tension should be adjusted during installation. If the pre-tension is not large enough, the transmission capacity of the synchronous belt will be greatly reduced, and the pulley will heat up rapidly, causing wear and tear on the accessories. Conversely, if the pre-tension is too large, the service life of the synchronous belt will be reduced. Therefore, appropriate and reasonable pre-tension is the prerequisite for ensuring the normal operation of the synchronous belt.

6. After the synchronous belt is replaced, the robot must be reset to zero by a professional technician before it can be used normally. Otherwise, the robot's zero point will be lost and danger may occur.

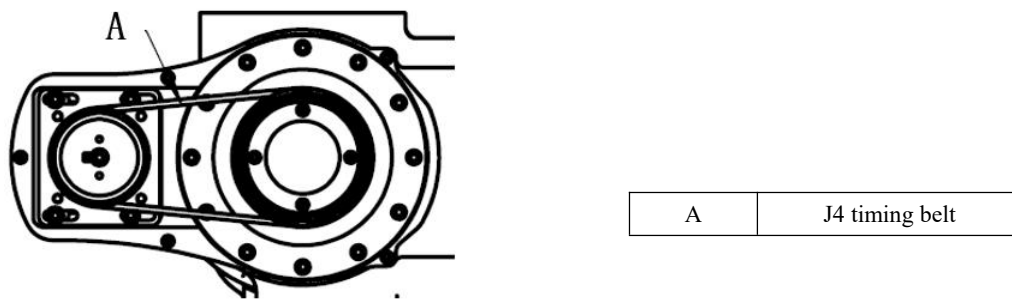
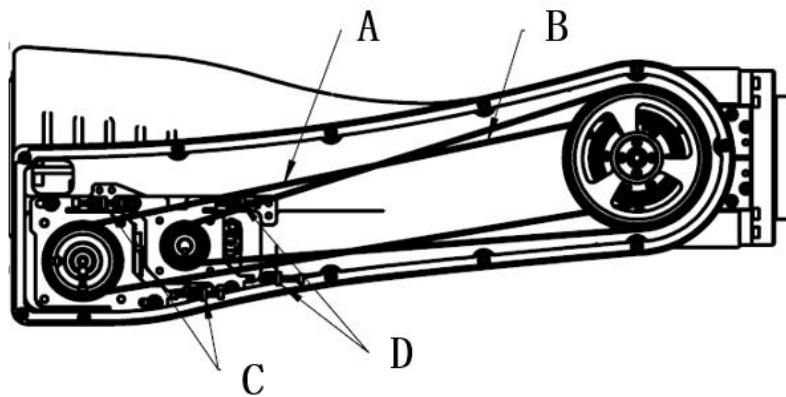

Figure 2.18 SA6/1440H drive housing assembly synchronous belt structure diagram



| | |
|---|------------------|
| A | J5 timing belt |
| B | J6 timing belt |
| C | J5 tension plate |
| D | J6 tension plate |

Figure 2.19 SA6/1440H wrist synchronous belt structure diagram

| Joint axis | Minimum value (Hz) | Maximum value (Hz) | Minimum value (Hz) | Maximum value (Hz) |
|------------|--------------------|--------------------|--------------------|--------------------|
| J4 | 133 | 139 | 113 | 118.1 |
| J5 | 40.3 | 42.3 | 34.2 | 35.9 |

| | | | | |
|----|------|------|------|------|
| J6 | 53.2 | 55.8 | 45.2 | 47.4 |
|----|------|------|------|------|

Note: The tension plates under the J5 and J6 axes are removed during delivery. If adjustment is required on site, the two upper tension plates can be used as a group to adjust the J5 and J6 belts respectively.

2.6 Dismantling and scrapping

All used greases, oils and dead batteries must be disposed of in accordance with the laws in force in the country where the robot and control unit are installed. If disposing of parts made of different materials, they must first be grouped according to their nature (i.e. all iron parts in one group, all plastic components in another) and then disposed of accordingly. These parts must also be disposed of in accordance with the laws in force in the country where the robot and control unit are installed.

Work on industrial robots is only allowed to be performed by professionally qualified personnel, that is, personnel who have received professional training in the operation of STEP robots and obtained a certificate of qualification, are familiar with the prescribed standards, and can therefore make correct judgments about the work to be performed and can identify potential dangers.

When dismantling and scrapping robots, operators must pay attention to safety and wear at least the following items when working: work clothes, safety shoes, and safety helmets suitable for the work content.

2.6.1 Precautions for robot dismantling and scrapping

During the dismantling and scrapping of some SA series robots, if you have any questions about the safety and precautions related to the dismantling and scrapping of the robots, you can consult STEP's after-sales service personnel.

Things to note when dismantling and scrapping robots:

1. The robot must be adjusted to the limit position to prevent the robot arm from slipping and injuring the operator or nearby people during the disassembly process;
2. The power supply, air pressure source, and hydraulic source connected to the robot are all disconnected;
3. The energy of the energy storage component is fully released to avoid instantaneous release of stored energy, which may cause injury to workers;
4. The lubricating grease in the oil chamber can be completely drained after the robot has cooled to room temperature to prevent the operator from being scalded by the high oil temperature;
5. The motor must be removed safely to avoid motor brake failure, which may cause the robot to harm the operator;
6. The battery must be removed safely to prevent explosion during the removal process.

2.6.2 Precautions for motor removal and scrapping

1. The robot must be adjusted to the limit position.
2. Completely disconnect the motor and pipeline connections.
3. If you dismantle the robot immediately after it is powered off and stops running, you must wear protective gloves to avoid burns caused by overheating of the motor.
4. The motor can be unplugged only after the robot has cooled to room temperature to prevent the high pressure in the oil chamber from causing the oil to spray out and hit the operator.

2.6.3 Notes on battery removal and disposal

1. The robot must be adjusted to the limit position.
2. When removing the battery, be careful to disconnect all wires connected to the battery.
3. After removing the battery, separate the positive and negative poles and provide insulation protection (you can use insulating tape or heat shrink tube) to prevent the battery from overheating and explosion.

Schedule

The robot also needs regular maintenance to ensure its normal function. Tables 1 and 2 specify the main inspection and maintenance activities and time intervals:

The inspection time periods are divided into daily, 1 month, 3 months, 6 months and 1 year. However, if the machine operation time exceeds 320 hours in a month, the inspection interval of each item should be calculated as 1 month for every 320 hours.

Table 1 Inspection items when power is OFF

| Inspection items | Inspection location | dai ly | 1 month 320h | 3 months 960h | 6 months 1920h | 1 year 3840h |
|------------------|-----------------------|-----------|--------------------|---------------------|----------------------|-----------------|
| | Fixture mounting | √ | √ | √ | √ | √ |
| | Robot base mounting | √ | √ | √ | √ | √ |
| | Surface cover | | | √ | √ | √ |
| | Screws for motors, | | | | | √ |
| | The robot has its own | | | | | |
| | Robot Cable | | | | | |
| | Controller cable | √ | √ | √ | √ | √ |
| | Robot outer surface | √ | √ | √ | √ | √ |
| | Cable surface | √ | √ | √ | √ | √ |

| | | | | | | |
|---------------------------------------------------------------------------------------------------------------------------|--------------------------|---|---|---|---|---|
| Check whether the timing belt is abnormally worn or loose. If so, replace it or re-tighten it. | Inside the wrist | | | | | √ |
| Check whether there is any thin oil seeping out of the joints in the form of water droplets. If so, please wipe it clean. | Joint surfaces | √ | √ | √ | √ | √ |
| For equipment that runs continuously for 24 hours, whether the J1~J4 reducers are depressurized and vented regularly. | J1~J4 joints | | | √ | √ | √ |
| Check whether the information label is missing or not. If so, please contact after-sales service. | Robot surface | | | | | √ |
| Check whether the hard limit and buffer block are damaged. If damaged, please contact after-sales service. | Hard limit of each joint | | | | | √ |
| Grease replacement | | | | | | |
| Battery | | | | | | |

Before the robot starts working every day, when the power is turned on, please perform inspection work according to the table below.

Table 2 Inspection items when power is on

| Inspection items | Inspection location | daily | 1 month 320h | 3 months 960h | 6 months 1920h | 1 year 3840h |
|------------------------------------------------------------------------------------------------------------------------------------|------------------------------------------------------|-------|-----------------|------------------|-------------------|-----------------|
| Check whether the teach pendant displays normally and whether the emergency stop button is usable. If there is any problem, please | Teach pendant display screen, emergency stop button. | √ | √ | √ | √ | √ |

| | | | | | | |
|--------------------------------------------------------------------------------------------------------------------------------------------------|----------------------------|---|---|---|---|---|
| repair or replace it. | | | | | | |
| In the enabled state, push each axis by hand to see if there is any shaking. | Each joint | | | | √ | √ |
| During operation, check whether each axis has any abnormal noise or vibration. If so, please contact the manufacturer. | Each joint | √ | √ | √ | √ | √ |
| Check whether the enable button is lit normally. | Enable button | √ | √ | √ | √ | √ |
| Check whether each air pipe is connected properly and whether there is any leakage. If there is any leakage, please re-tighten it or replace it. | Trachea, trachea connector | √ | √ | √ | √ | √ |

Note: When checking whether there are any abnormal noises or vibrations on each axis during operation, please be sure to stay in a safe area to avoid accidents.

Technical Support

◆ Technical Services

Shanghai STEP Robotics Co., Ltd. is happy to provide information about the operation and operation of the machine, and can help you troubleshoot and provide detailed consultation. If your robot fails during production, please contact our service organization immediately and provide the following information as much as possible:

- ◇ Robot model and serial number
- ◇ Control system model and serial number
- ◇ Control system system version number
- ◇ Additional software packages (optional)
- ◇ Existing applications
- ◇ Other additional devices (positioner, guide rail, etc., optional)
- ◇ Description of the problem, duration and frequency of the fault, etc.

◆ Contact Details

Shanghai STEP Robotics Co., Ltd.

Address: No. 1518 Siyi Road, Jiading District, Shanghai

Tel: 021-80158679

Fax: 021-31010674

Email: robot@steprobots.com

Zip code: 201801

<http://www.stepelectric.com>