

# SC20 O&C Controller Hardware

## Manual

Sharing the Convenience and  
Happiness of a Smart Society  
with Humanity



## Revised History

The manual number can be found at the bottom of the front cover.

Type of Manual	Issue date	Manual No.	Revision description
SC20 Hardware Manual	V1.0	First edition	
SC20 Hardware Manual	V1.2		Add content and correct errors Update the wiring section
SC20 Hardware Manual	V1.3		Match with the new STEP AS version 1.1
SC20 Hardware Manual	V1.4		Update the content of the local extension module and correct some errors

## Preface

First of all, thank you for purchasing the SC series of programmable logic controllers and extension modules developed and manufactured by STEP Electric!

Always read this manual and the relevant instructions described in this manual carefully prior to using the product, and operate it properly with due regard to safety.

### Type of Manual

- The types of SC series manuals are as follows. Please refer to the corresponding manual according to the application.
- The manual can be downloaded from the Company's homepage

<http://www.step-sigriner.com.cn>.

### Manuals used for the SC series products

NO.	Manual name	Content
1.	SC Series Controller Software Operation Manual	Software installation, configuration, debugging, coding, etc.
2.	SC Series Controller Software Programming Manual	Motion control programming, commonly used programming libraries, instructions, etc.
3.	SC20 Controller Hardware Manual	SC20 related hardware interface, wiring and maintenance
4.	SC30 Controller Hardware Manual	SC30 related hardware interface, wiring and maintenance
5.	SC Series Controller Visual Interface Operation Instruction	Visual interface related operation and programming

## Copyright & Trademark

- The copyright of the manual is reserved by the Shanghai STEP Electric Corporation.
- Unauthorized reproduction of this manual is strictly prohibited.

- The names of other companies and products are trademarks or registered trademarks of those companies respectively.

**Contents**

Chapter 1	Prior to Use .....	1
1.1.	Precautions and explanations .....	2
1.2.	Product naming convention .....	3
Chapter 2	Overview .....	5
2.1.	Basic system specifications .....	6
2.1.1.	SC20 system overview .....	6
2.1.2.	Type of unit .....	6
2.1.3.	Limit on the number of extension units .....	7
2.2.	Programming tool connection .....	8
2.2.1.	Software operating environment and applicable cables .....	8
Chapter 3	System Components and Definitions .....	11
3.1.	Names and interface definitions of the SC20 Controller .....	12
3.1.1.	Names and functions .....	12
3.1.2.	Names and functions of the status LEDs .....	13
3.1.3.	Definitions of serial ports and power interfaces .....	14
3.1.4.	Definition of analog-digital hybrid I/O interfaces .....	14
3.1.5.	Definition of locally optional common I/O board interface .....	15
3.1.6.	Interface definition for locally optional axis-controlled high-speed counter boards .....	16
3.2.	Extension unit .....	17
3.2.1.	Name and function of each part of the SC20 Local Extension Unit .....	17
3.2.2.	Interface definition of local extension I/O boards .....	18
3.3.	IO status LED display .....	21
3.4.	Module silkscreen description .....	21
Chapter 4	Installation .....	22
4.1.	Installation of the SC20 Series .....	23
4.1.1.	Installation environment and space .....	23
4.1.2.	Steps for unit installation .....	25
4.1.3.	Dismantling of the unit .....	26
Chapter 5	Wiring .....	27
5.1.	Suggestions for cabling .....	28
5.1.1.	Shielded cable grounding .....	28
5.1.2.	Cabling requirements .....	28
5.2.	Wiring of the power supply .....	30
5.2.1.	General considerations .....	30
5.2.2.	Power supply for SC20 Controller .....	31
5.2.3.	Grounding .....	31
5.3.	Wiring of the network .....	32
5.4.	General wiring specifications for I/O modules .....	33
5.4.1.	General considerations for I/Os .....	33
5.4.2.	Wiring on the input side .....	33
5.4.3.	Axis-controlled high-speed counter input wiring .....	36

5.4.4.	Wiring on the output side .....	38
5.4.5.	RS485 communication terminal resistor wiring .....	40
5.4.6.	CAN communication terminal resistor wiring .....	41
5.4.7.	Instructions for DI input wiring .....	42
5.5.	Module Terminal Signal Arrangement and Cable Production .....	43
5.5.1.	Cable production .....	43
5.5.2.	Signal arrangement and definition of terminals for serial ports and power interfaces 45	46
5.5.3.	Signal arrangement and definition of analog-digital hybrid I/O board terminals	46
5.5.4.	Arrangement and definition of signals of locally optional general I/O board terminals 49	49
5.5.5.	Arrangement and definition of signals for locally optional axis-controlled high-speed counter board terminals .....	51
5.5.6.	Arrangement and definition of the signals of the local extension digital input board terminals .....	54
5.5.7.	Arrangement and definition of the signals of the local extension digital output terminals 58	58
5.5.8.	Arrangement and definition of the signals of the local extension digital I/O terminals 60	60
5.5.9.	Arrangement and definition of the signals of the local extension analog I/O board terminals .....	62
5.6.	Safety precautions .....	64
5.6.1.	Safety precautions .....	64
5.6.2.	Momentary interruption .....	64
Chapter 6	Confirmation of Wiring .....	65
6.1.	Suggestions for safety circuits .....	66
6.2.	Confirmations when wiring .....	67
6.3.	Power ON/OFF operation .....	68
6.3.1.	Power ON operation .....	68
6.3.2.	OFF operation .....	68
Chapter 7	Confirmations Prior to Operation .....	69
7.1.	Confirm that the power ON and network is created .....	70
Chapter 8	USB Flash Disk Operation .....	71
8.1.	The way to insert the USB flash disk .....	72
8.2.	U-copy file operations .....	73
Chapter 9	System Reset .....	74
9.1.	Reset the unit using the RESET button on the SC20 main unit .....	75
Chapter 10	Troubleshooting .....	76
10.1.	System status .....	77
10.2.	Solutions for exceptions .....	77
Chapter 11	Maintenance & Inspection .....	78
11.1.	Inspection .....	79
Chapter 12	Specifications and Dimensional Drawings .....	80
12.1.	Specification of the application environment .....	81

12.2.	Performance specification .....	82
12.3.	Specification of the SC20 Controller body .....	83
12.3.1.	High-speed input specification of the SC20 Controller .....	83
12.3.2.	Specification of the high-speed (pulse) output of the SC20 Controller .....	83
12.3.3.	Input specifications of the SC20 Controller .....	84
12.3.4.	Output specifications of the SC20 Controller .....	86
12.4.	Specification of the extension module .....	87
12.4.1.	Specifications for local extension digital input modules .....	87
12.4.2.	Specifications for local extension digital output modules .....	88
12.4.3.	Specifications of local extension I/O modules .....	88
12.4.4.	Specifications of local extension analog modules .....	90
12.5.	Communication specifications .....	92
12.5.1.	USB port specifications .....	92
12.5.2.	Specifications of COM ports .....	92
12.5.3.	LAN port specifications .....	93
12.6.	Other specifications .....	94
12.6.1.	USB flash disk specifications .....	94
12.7.	Dimensional drawing .....	95
12.7.1.	Dimensional drawing of the SC20 Controller .....	95
12.7.2.	Dimensional drawing of the SC20 local extension module .....	95
Chapter 13	Appendix 1 Notes on Upgrade/Warranty .....	96
13.1.	Warranty .....	97
13.2.	Repair and maintenance .....	99
13.3.	Technical Services .....	100

















# Chapter 1 Prior to Use

---

## 1.1. Precautions and explanations

The following is a description of the matters that must be observed in order to prevent hazards to persons or damage to property.

- The hazards and the extent of the damage caused when used in the incorrect way are classified and described below.

 警告 WARNING	"Matters that may result in death or serious injury".
 注意 Note	"Matters that may result in minor injury or cause damage to property".
	Matters that cannot be performed.
	Matters that must be performed.
 <b>WARNING</b>	
	<ul style="list-style-type: none"> <li>Please take safety measures on the outside of the product so that the whole system can be secured in the event of a malfunction of the product or in the event of an exception due to external causes.</li> </ul>
	<ul style="list-style-type: none"> <li>Never use in an environment containing combustible gases. Failure to do so may cause an explosion.</li> </ul>
	<ul style="list-style-type: none"> <li>DO NOT throw this product into a fire, or else it may cause the battery and electronic parts to break.</li> </ul>
 <b>Notes</b>	
	<ul style="list-style-type: none"> <li>To prevent any excessive temperature rise and smoke, there should be some allowance for the parameters used in relation to the guaranteed characteristics and performance parameters of the product.</li> </ul>
	<ul style="list-style-type: none"> <li>DO NOT disassemble or modify, otherwise unusual temperature rise and smoke may occur.</li> </ul>
	<ul style="list-style-type: none"> <li>DO NOT touch the terminals while the power is ON. Failure to do so may result in electric shock.</li> </ul>
	<ul style="list-style-type: none"> <li>Please provide an E-stop circuit and interlock circuit in the external circuit.</li> </ul>
	<ul style="list-style-type: none"> <li>Please connect the wires and connectors properly. Poor contact between the cable and the connector may lead to unusual temperature rise and smoke.</li> </ul>
	<ul style="list-style-type: none"> <li>DO NOT operate (connect, disassemble, etc.) with the power on. Failure to do so may result in electric shock.</li> </ul>
	<ul style="list-style-type: none"> <li>The protection function of the unit may be damaged if it is not used in the manner specified by the Company.</li> </ul>



- The product has been developed and manufactured for use in industrial environments.

## 1.2. Product naming convention

### SC Series Naming Convention

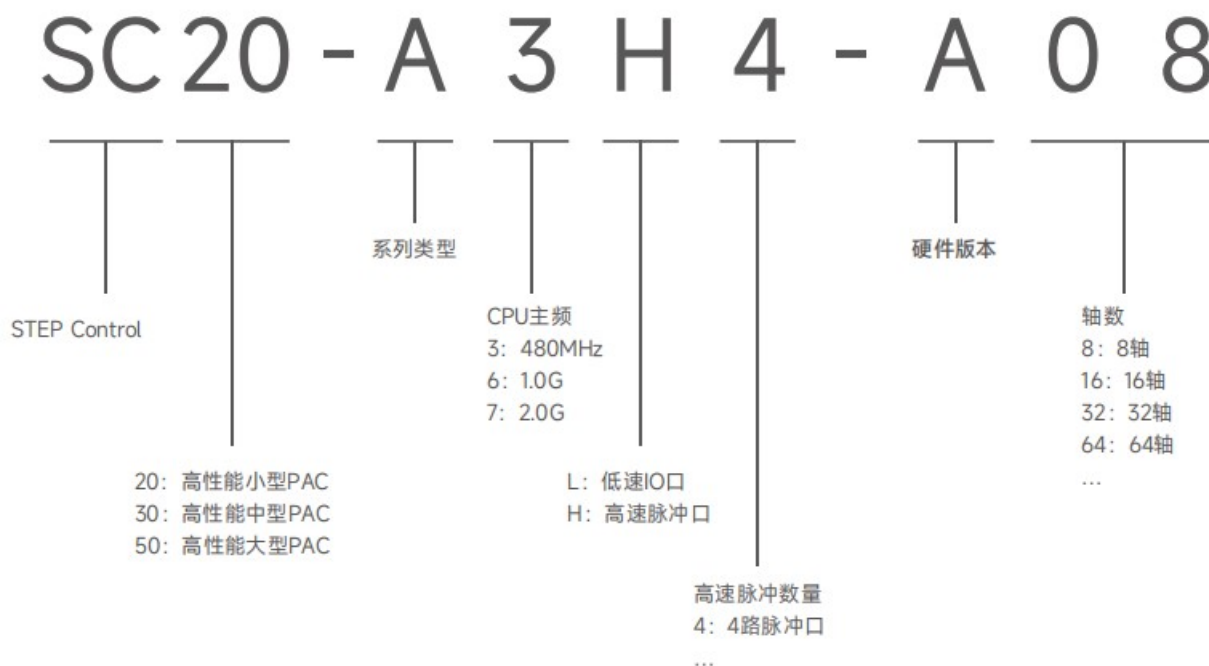

20: 高性能小型 PAC	20: High-performance mini PAC
30: 高性能中型 PAC	30: High-performance medium-sized PAC
50: 高性能大型 PAC	50: High-performance large PAC
系列类型	Type of series
CPU 主频	CPU dominant frequency
L: 低速 IO 口	L: Low-speed IO port
H: 高速脉冲口	H: High-speed pulse port
高速脉冲数量	Number of high speed pulses
4: 4 路脉冲口	4: 4-channel pulse port
硬件版本	Hardware version
轴数	Number of axes
8: 8 轴	8: 8-axis
16: 16 轴	16: 16-axis
32: 32 轴	32: 32-axis
64: 64 轴	64: 64-axis

\*: As a reference for hashrate and ability to carry axes. The number of axes will vary slightly depending on the software implementation.

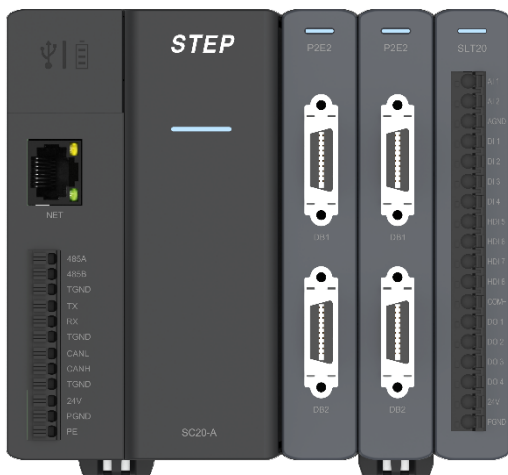

SC20-A3H of the SC20 series



SC30-B6H of the SC30-B series

## Chapter 2 Overview

---

## 2.1. Basic system specifications

### 2.1.1. SC20 system overview



Rendering of two versions of SC20 with different optional modules and local extension boards

The SC20 Series Motion Controller is a compact controller in a modular design.

#### ■ Strong scalability

- ◆ Each controller supports the local extension of 8 extension modules. The local extension module enables module extension via internal bus protocols and supports digital I/O modules and analog I/O modules. Analog I/O module employs a 12-bit resolution converter chip to ensure highly accurate data acquisition
- ◆ Remote extension of the rack is possible via various industrial fieldbuses such as EtherCat, CAN Open, etc.
- ◆ Support 1 Ethernet connection port, and EtherCat compatible.

#### ■ Powerful control functions

- ◆ Support for 16-axis motion control via EtherCat bus
- ◆ Feature single-axis acceleration and deceleration control, electronic gear, electronic cam, CNC, robotics and other motion control functions
- ◆ Basic single-axis positioning is also possible via high-speed IO at up to 4 Mbps.

### 2.1.2. Type of unit

#### ■ Body of the Controller

Type	Unit	Function	Product silkscreen
Body of the Controller	SC20 Controller	16-axis motion controller Transistor NPN output type	SC20_A
	Locally selectable axis-controlled high-speed counter	For 2ch motor pulse	P2E2

	module (optional)	control	
	Local optional general digital I/O module (optional)	24V 12ch digital input, 4ch digital output.	X12Y4
	Analog-digital hybrid I/O interfaces	2ch analog input, 4ch digital input, 4ch high-speed speed input, 4ch digital output.	SLT20

### ■ Local Extension Units

Type	Unit	Function	Product silkscreen
Digital modules	General digital output module for local extension	24V 16-channel output Transistor NPN type	Y16
	General digital input module for local extension	24V 16-channel input	X16
	General digital I/O modules for local extension	24V 8 inputs and 8 outputs	X8Y8
Analog modules	General analog I/O modules for local extension	0~10V 4 inputs and 2 outputs	AX4Y2

Type	Unit	Function	Product silkscreen
Digital modules	EtherCAT extended remote digital I/O hybrid module	24V 8-channel bidirectional configurable 16 DIs and 8 DOs MOS tube output type	SX-CD433-HR
Hybrid modules	EtherCAT extended remote I/O hybrid module	24V 8 DIs and 8 DOs 4 AIs and 4 AOs	SX-D330A22-HR

#### 2.1.3. Limit on the number of extension units

Up to **8** general extension units can be installed on the right side of the SC20 controller.

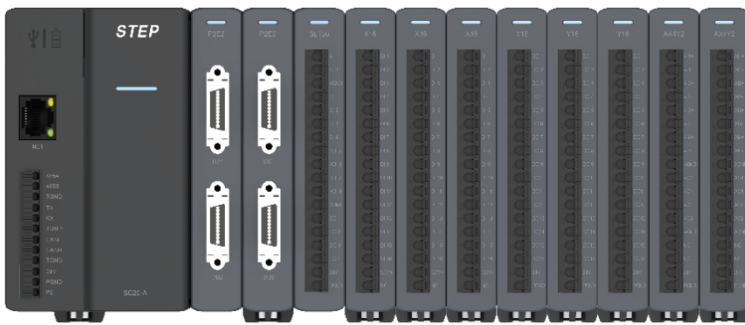
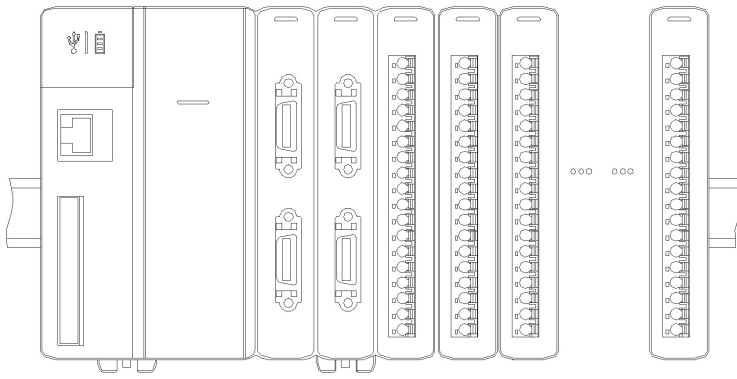

## 2.2. Programming tool connection

### 2.2.1. Software operating environment and applicable cables

The supplied IDE software for programming is STEP Automation Studio. The operating environment of the relevant software is the computer Windows platform. Refer to the *SC Series Controller Software Manual* for details.

The SC20 can interact with STEP AS in three ways (e.g. program download, debugging, monitoring, etc.):

Type of connections	Type of cables	Remarks
USB	USB-A	Master-slave compatible, auto identification, USB 2.0
COM	Standard COM port	COM1 port
Ethernet	Ethernet 100Base-TX	Max. length 50m

Cable jumper:

- The SC20 supports a master-slave USB interface, which allows it to be used as a USB slave when connected to a PC. Please use a commercially available cable with both heads being USB-A.



- The Ethernet cable connecting the controller to the PC supports auto-negotiation, AB registered jack direct connection or crossover. Just use a standard network cable. To make your own cable, please refer to the diagram below.

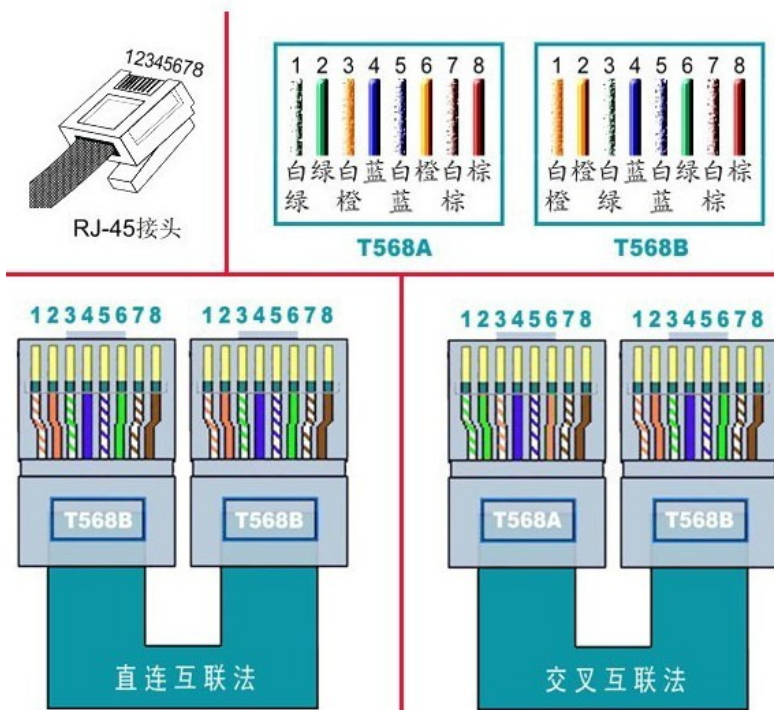



RJ-45 接头	RJ-45 connectors
白绿	White and green
绿	Green
白橙	White and orange
蓝	Blue
白蓝	White and blue
橙	Orange
白棕	White and brown
棕	Brown
白橙	White and orange
橙	Orange
白绿	White and green
蓝	Blue
白蓝	White and blue
绿	Green
白棕	White and brown
棕	Brown
直连互联法	Direct interconnection method
交叉互联法	Cross-interconnection method
CAT5e/6 网线	CAT5e/6 network cable

- COM connection

As shown in the diagram below, connect the Tx Rx TGND on the SC20 side to the RxD TxD GND of the PC COM port based on the definition of the serial port.

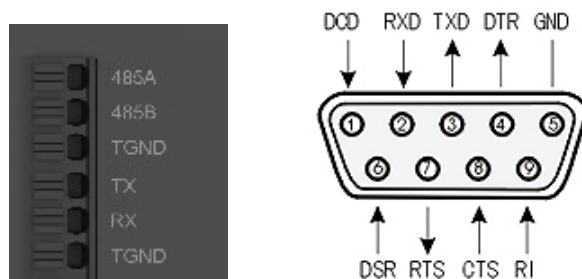

# **Chapter 3 System Components and Definitions**

---

### 3.1. Names and interface definitions of the SC20 Controller

#### 3.1.1. Names and functions

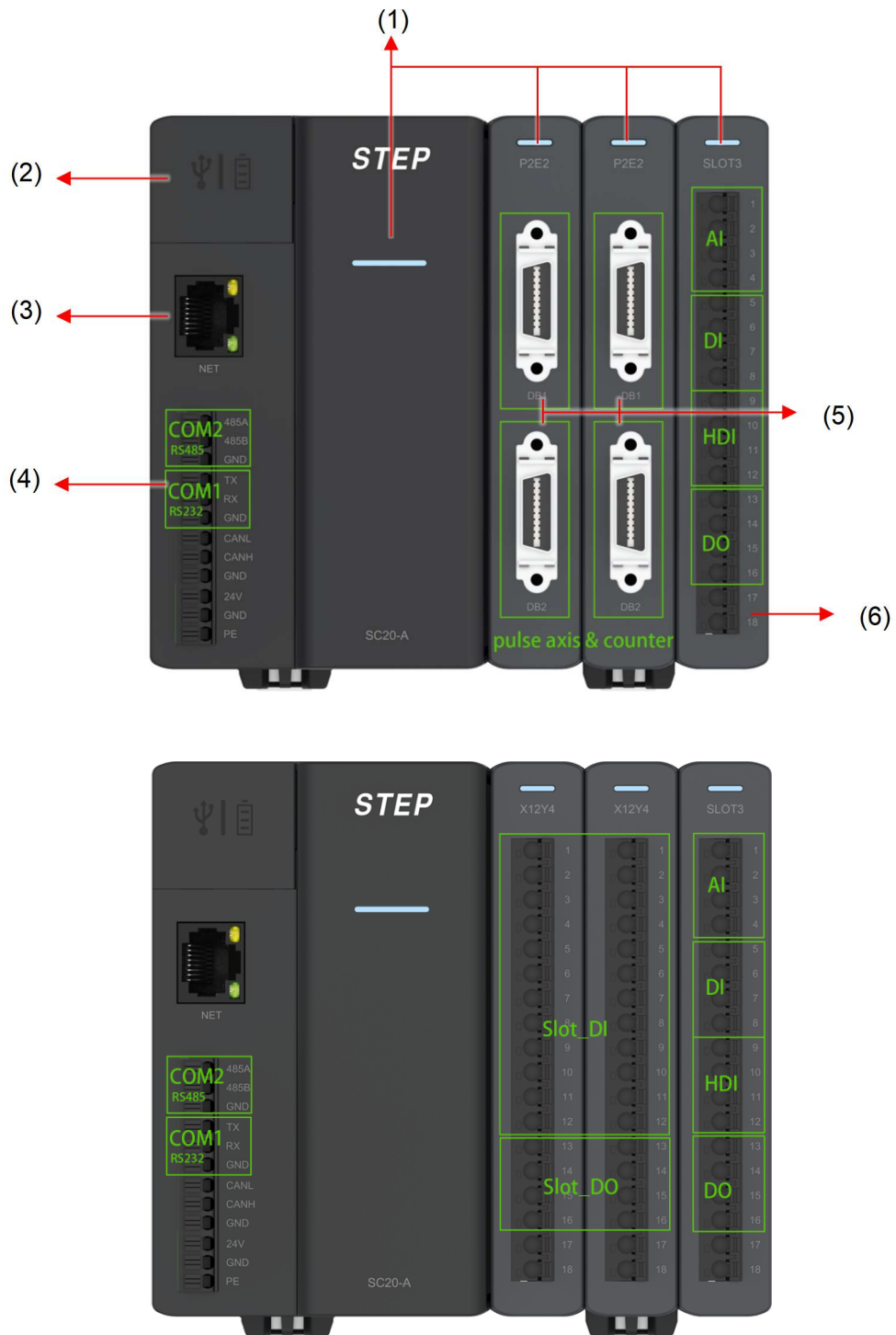

No.	Name	Function
1	Status LED	It is the unit status LED Please refer to " <a href="#">Names and functions of the status LEDs</a> "
2	Flip-top cover (includes USB-A socket, coin cell battery case and RESET button)	USB master and slave, which can be connected to a USB flash disk as a master, and download debugging projects as a slave; RESET button; mainly refer to "Chapter IX System Reset"; Powering of the system clock by batteries;
3	LAN port (EtherCat and Ethernet supported)	Default IP address 192.168.0.11 Status LED Please refer to " <a href="#">Names and functions of the status LEDs</a> " The protocol will be extended later
4	Serial port and power interface	It is an interface for serial communication and 24V DC power supply Please refer to " <a href="#">Signal arrangement and definition of terminals for serial ports and power interfaces</a> "
5	Analog-digital hybrid I/O interfaces	2ch analog input, 4ch digital input, 4ch high-speed digital input, 4ch digital output. Please refer to " <a href="#">Signal Arrangement and Definition of Analog-Digital Hybrid I/O Terminals</a> "
6	Locally optional Axis-controlled high-speed counter module interface	Divisible into 2 x 2ch axis-controlled motor interfaces (together forming a 4ch motor pulse control interface) Please refer to " <a href="#">Arrangement and Definition of Locally Optional Axis-controlled High-speed Counter Board Terminals</a> "
7	Locally optional General I/O module interface	24V 12ch digital inputs and 4ch digital outputs Please refer to " <a href="#">Arrangement and Definition of the Locally Optional General I/O Board Terminals</a> ".

### 3.1.2. Names and functions of the status LEDs

No.	Name	LED Color	Function
1	Module status LED display	LED tricolor light Red, Blue, Yellow	Display the current module status Refer to the " <a href="#">System status</a> " for details
2	EtherCat, Ethernet communication status LED	Green and yellow.	For normal connection: the green LED is always ON. For data transmission and reception: green and yellow LEDs flash simultaneously. In case of fault: the orange LED is always

ON, or both are OFF.

**3.1.3. Definitions of serial ports and power interfaces**

No.	Name	Function	Name in STEP AS
1	485A	RS485 communication +	COM2
2	485B	RS485 communication -	
3	TGND	Power reference ground	
4	RX	RS232 receiver	COM1
5	TX	RS232 transmitter	
6	TGND	Power reference ground	
7	CANH	CAN+	CAN
8	CANL	CAN-	
9	TGND	Power reference ground	
10	24V	Power input 24V	
11	GND	Power input ground	
12	PE	Ground	

**3.1.4. Definition of analog-digital hybrid I/O interfaces**

No.	Name	Function
1	AI1	Analog input 1
2	AI2	Analog input 2
3	AGND	Analog ground
4	DI1	Digital input
5	DI2	Digital input
6	DI3	Digital input
7	DI4	Digital input
8	HDI5	High-speed digital input
9	HDI6	High-speed digital input
10	HDI7	High-speed digital input
11	HDI8	High-speed digital input
12	COM+	Common terminal (only 24V+ supported)
13	DO1	Digital output
14	DO2	Digital output
15	DO3	Digital output
16	DO4	Digital output
17	24V	Supplementary power input
18	PGND	Supplementary power ground

**3.1.5. Definition of locally optional common I/O board interface**

No.	Name	Function
1	DI1	Digital input
2	DI2	Digital input
3	DI3	Digital input
4	DI4	Digital input
5	DI5	Digital input
6	DI6	Digital input
7	DI7	Digital input
8	DI8	Digital input
9	DI9	Digital input
10	DI10	Digital input
11	DI11	Digital input
12	DI12	Digital input
13	DO1	Digital output
14	DO2	Digital output
15	DO3	Digital output
16	DO4	Digital output
17	24V	Supplementary power input
18	PGND	Supplementary power ground

### 3.1.6. Interface definition for locally optional axis-controlled high-speed counter boards

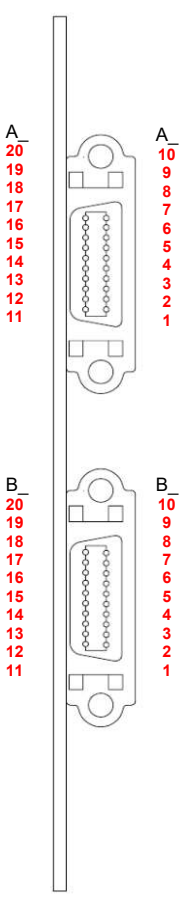
Arrangement of the optional axis-controlled high-speed counter board terminals	NO.		Name	Purpose
	A_	B_		
	1	1	ECA1+	Encoder A
	2	2	ECA1-	Encoder A
	3	3	ECB1+	Encoder B
	4	4	ECB1-	Encoder B
	5	5	ECZ1+	Encoder Z
	6	6	ECZ1-	Encoder Z
	7	7	OPC	Reserved high-speed DI+
	8	8	PULS	Reserved high-speed DI-
	9	9	SRV_COIN	Servo positioning completion DI
	10	10	ALARM	Servo alarm DI
	11	11	+5V_ENC	Encoder power supply
	12	12	EGND	Encoder reference ground
	13	13	DR+	Direction of command
	14	14	DR-	Direction of command
	15	15	PU+	Command pulse
	16	16	PU-	Command pulse
	17	17	24V	Power output
	18	18	GND_24V	Reference ground
	19	19	SRV_ON	Enable servo DO
	20	20	CLEAR	Clear servo alarm DO

## 3.2. Extension unit

### 3.2.1. Name and function of each part of the SC20 Local Extension Unit

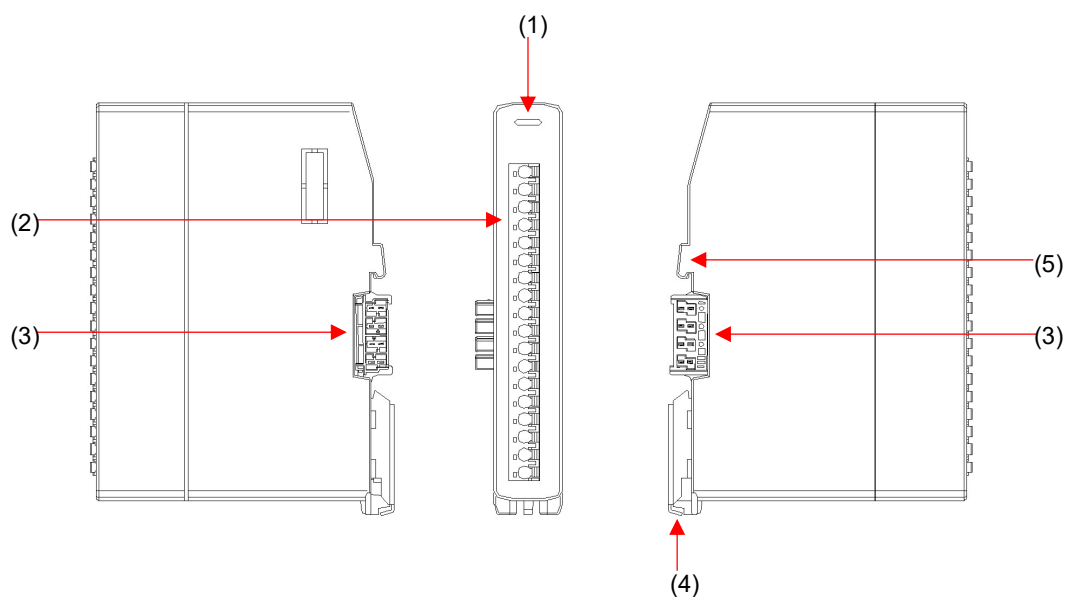

No.	Name	Function
1	Status display LED	Display of module connection status by LEDs
2	I/O connectors (includes IO status LED display)	Connection input and output devices Please refer to the " <a href="#">Definition of the Local Extension Digital I/O Board Interface</a> " Refer to " <a href="#">IO status LED display</a> "
3	Power input interface	Offers the stable power supply with bottom bus connection
4	DIN hook	A hook used to fix the body to the DIN rail.
5	DIN-rail mounting part	A part that is mounted on the DIN rail.

### 3.2.2. Interface definition of local extension I/O boards

#### ■ Interface definition of local extension digital input boards

No.	Name	Function
1	DI1	Digital input
2	DI2	Digital input
3	DI3	Digital input
4	DI4	Digital input
5	DI5	Digital input
6	DI6	Digital input
7	DI7	Digital input
8	DI8	Digital input
9	DI9	Digital input
10	DI10	Digital input
11	DI11	Digital input
12	DI12	Digital input
13	DI13	Digital input
14	DI14	Digital input
15	DI15	Digital input
16	DI16	Digital input
17	COM	Common terminal
18	NC	Empty pin

SL-X16A01 only supports low level input, and COM is connected to 24V.

SL-X16C01 only supports low/high level inputs, and COM is connected to 24V or 0V.

#### ■ Interface definition of local extension digital output boards

No.	Name	Function
1	DO1	Digital output
2	DO2	Digital output
3	DO3	Digital output
4	DO4	Digital output
5	DO5	Digital output
6	DO6	Digital output
7	DO7	Digital output
8	DO8	Digital output
9	DO9	Digital output
10	DO10	Digital output
11	DO11	Digital output
12	DO12	Digital output
13	DO13	Digital output
14	DO14	Digital output
15	DO15	Digital output
16	DO16	Digital output

17	24V	IO supplementary power
18	PGND	IO reference ground
SL-Y16A01 only supports low level outputs.		

#### ■ Interface definition of local extension digital I/O boards

No.	Name	Function
1	DO1	Digital output
2	DO2	Digital output
3	DO3	Digital output
4	DO4	Digital output
5	DO5	Digital output
6	DO6	Digital output
7	DO7	Digital output
8	DO8	Digital output
9	DI1	Digital input
10	DI2	Digital input
11	DI3	Digital input
12	DI4	Digital input
13	DI5	Digital input
14	DI6	Digital input
15	DI7	Digital input
16	DI8	Digital input
17	24V	IO supplementary power
18	PGND	IO reference ground
SL-X8Y8A01 supports low levels only.		

#### ■ Interface definition of local extension analog I/O boards

No.	Name	Function
1	AI1+	Analog input positive (+)
2	AI1-	Analog input negative (-)
3	AI2+	Analog input positive (+)
4	AI2-	Analog input negative (-)
5	AI3+	Analog input positive (+)
6	AI3-	Analog input negative (-)
7	AI4+	Analog input positive (+)
8	AI4-	Analog input negative (-)
9	AGND	Analog ground
10	AO1+	Analog output positive (+)
11	AO1-	Analog output negative (-)
12	AO2+	Analog output positive (+)
13	AO2-	Analog output negative (-)
14	AGND	Analog ground
15	NC	Empty pin

16	NC	Empty pin
17	24V	IO supplementary power
18	PGND	IO reference ground

### 3.3. IO status LED display

Name of module	IO status LED
Local communication module	Not supported, always OFF
Locally optional general I/O modules	Significant I/O bits, green LED is ON
Locally optional axis-controlled high-speed counter module	Not supported, N/A
Local extension digital input modules	Significant input bits, green LED is ON
Digital output module for local extension	Significant output bits, green LED is ON
Digital I/O modules for local extension	Significant I/O bits, green LED is ON
Analog I/O modules for local extension	Not supported, always OFF

### 3.4. Module silkscreen description

Name of module	Corresponding silkscreen
Local analog-digital hybrid I/O modules	SLT20
Locally optional general I/O modules	X12Y4
Locally optional axis-controlled high-speed counter module	P2E2
Local extension digital input modules	X16
Digital output module for local extension	Y16
Analog I/O modules for local extension	AX4Y2
Digital I/O modules for local extension	X8Y8

## Chapter 4 Installation

---

## 4.1. Installation of the SC20 Series

### 4.1.1. Installation environment and space

#### ■ Installation environment

When installing, use it within the general specifications.

- Ambient temperature: -20°C ~ +55°C
- Ambient humidity: 10%RH ~ 90%RH (no condensation at 25°C)
- IP grade: IP20
- Pollution class: IE33
- Altitude: up to 2000m above sea level
- EMC immunity level: according to EN 61000-6-X standard
- Installation position: in a control cabinet (made of metal with sufficient strength) in an environment with a protective structure of IP54 or greater.

Never use in the following environments:

- Places exposed to direct sunlight
- Places where rapid changes in temperature may cause condensation
- In environments with corrosive and flammable gases
- Places with a high concentration of dust, iron powder and salt
- Places and their environments where organic solvents such as petrol, thinner and alcohol or strong alkaline substances such as ammonia or sodium hydroxide are likely to adhere
- Places that may be subjected to direct vibration or shock and to direct splashing of water droplets
- In the vicinity of high-voltage power lines, high-voltage equipment, power lines, power equipment or equipment with transmitters such as amateur radio, and equipment generating high switching impulse currents (at least 100mm away)

#### ■ Action

- To avoid electrostatic damage, do not touch the pins of the connector directly.
- Please discharge any static electricity carried by the human body before operating.
- The connector on the side of the unit can only be connected to the SC20 series.
- Use copper wire with a temperature rating of 80°C or more.

#### ■ Considerations for cooling

- For cooling reasons, please install the unit in the direction shown below.
- DO NOT install the unit vertically, horizontally or upside down, as this may cause inadequate heat dissipation and result in abnormal internal heat generation.
- DO NOT install directly above equipment that generates a lot of heat such as heaters, transformers and high-capacity resistors.

#### ■ Installation space

- To ensure ventilation space, install the unit at a distance of 50mm or more from other equipment and

wiring ducts.

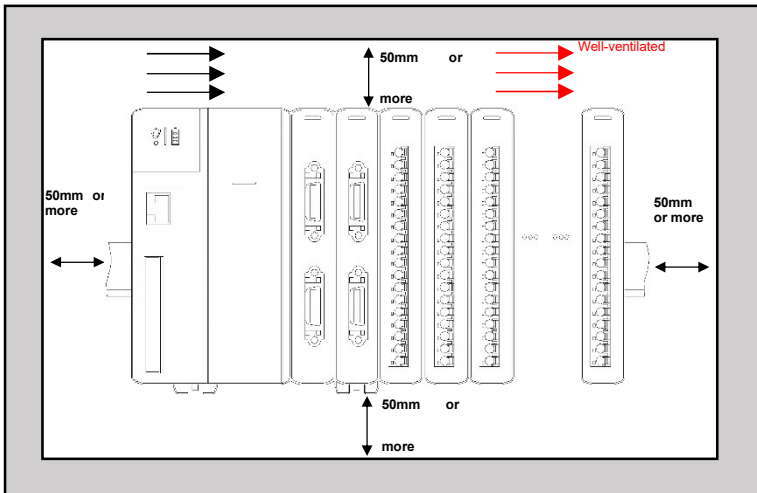

- DO NOT install directly above equipment that generates a lot of heat such as heaters, transformers and high-capacity resistors.
- To avoid the effect of radiated noise, install each unit with a distance of 100mm or more between the surface of the unit and power lines or electromagnetic switches. In particular, when mounting on the back of the control cabinet door, make sure that it is separated from other equipment by a certain distance.

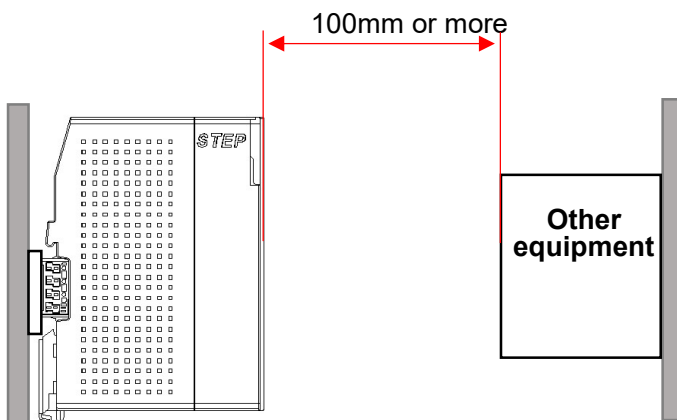

- To connect the tool software cable, make sure to leave more than 170mm of space on the mounting surface of the SC20 series.

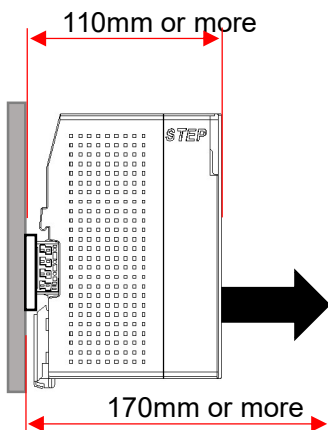

**4.1.2. Steps for unit installation**

1. Attach the bus connector to the rail.

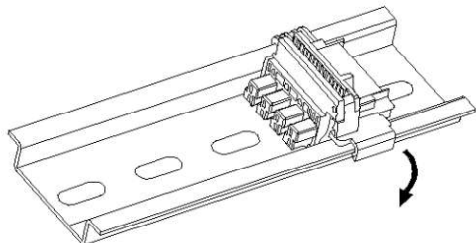

2. Slide the upper end of the unit mount onto the DIN rail and apply pressure to the side of the rail (a in the figure), then insert the lower end of the unit mount onto the DIN rail (b in the figure).

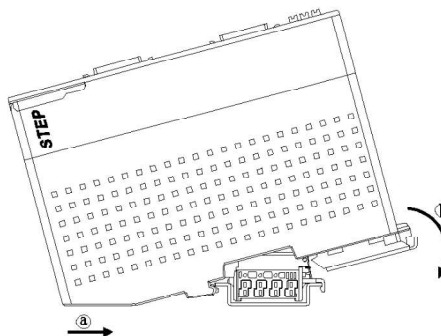

3. Installation is finished when a "click" is sounded and the metal latch snaps into the DIN rail.

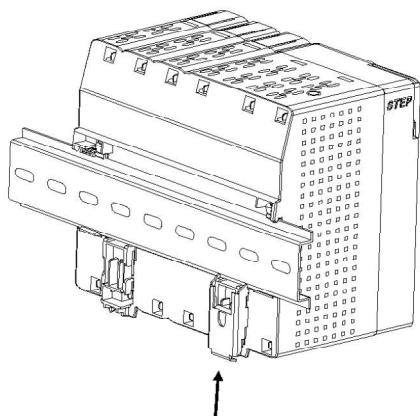

4. Snap the bus connector down onto the rail (a in the figure), then slide it to the SC20 side and insert the male connector into the female connector (b in the figure).

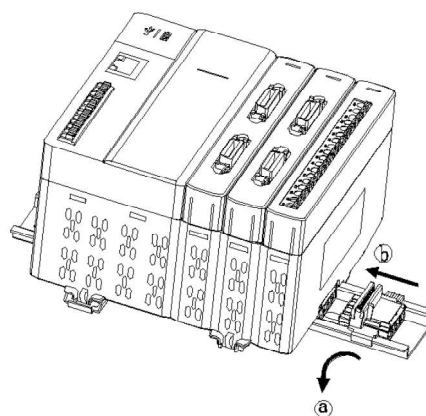

5. Slide the upper end of the extension I/O onto the DIN rail (a in the figure) and then insert the lower end onto the DIN rail (b in the figure).

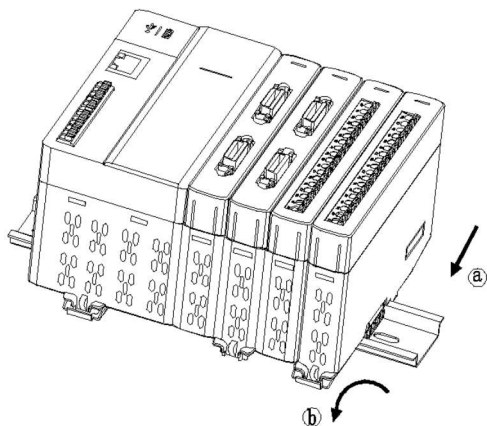

6. Snap the rail fixings into the rails (a in the figure) and tighten them with a screwdriver (b in the figure) and the installation is now completed.

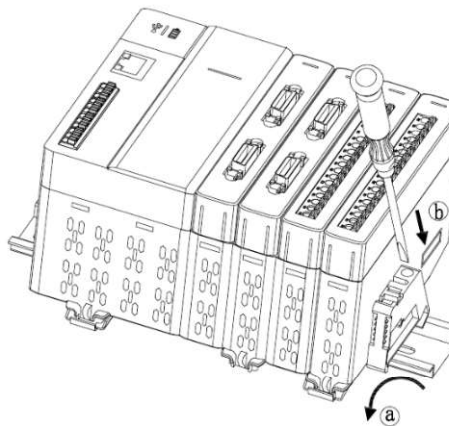

**4.1.3. Dismantling of the unit**

1. Unscrew the rail fixings with a screwdriver (a in the figure) and remove them from the rail (b in the figure).

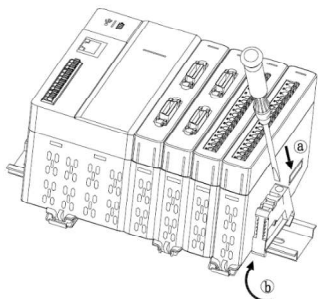

2. Snap the latch down with a screwdriver (a in the figure), then pry the screwdriver towards the extension unit and remove the metal latch at the bottom of the extension unit (b in the figure).

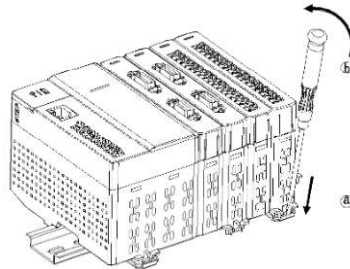

3. The extension I/O unit can be successfully removed by lifting up the latch side first (a in the figure) and then pushing it out to the other side (b in the figure)

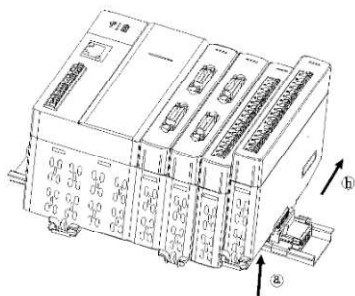

4. Pull the bus connector outwards and separate the male and female plugs (a in the figure); flip the lower end of the unit upwards and separate it from the rail (b in the figure).

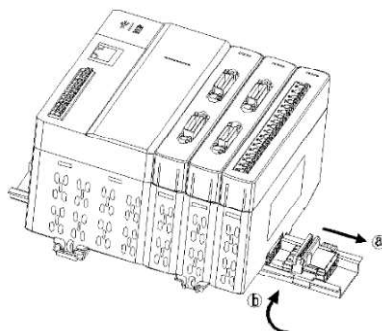

5. Snap the latch down with a screwdriver (a in the figure), then pry the screwdriver towards the SC20 controller to prise open the metal latch on the bottom of the unit (b in the figure).

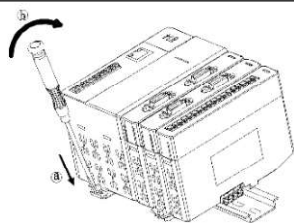

6. Pull the unit latch side up (a in the figure) and push it forward (b in the figure).

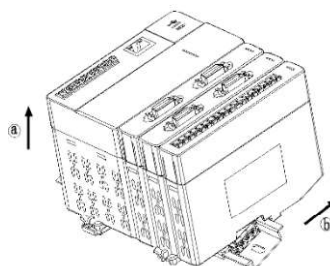

7. Removal is done by separating the unit from the DIN rail (a and b in the figure).

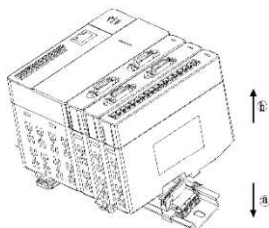

# Chapter 5 Wiring

---

## 5.1. Suggestions for cabling

### 5.1.1. Shielded cable grounding

Shielded cables must be used for high-speed I/O, analog I/O, fieldbuses and communication signals. Grounding as close as possible to the module so that the cables after grounding are not affected by electromagnetic induction from the cables before grounding. For the shielded cables, the shielding exposed after stripping part of the sheath should be grounded to the conductive backplate with as large an area as possible to ensure good contact.

The method of soldering the shielding part of the shielded cable to PVC wire and grounding it through its front end would increase the high-frequency reactance and make the shielding effect weaker. Care should be taken to avoid it.

The analog signals are only single-end grounded on the side near the module, while the high-speed I/O, fieldbus and communication signal cable shielded wire need to be grounded at both ends.

### 5.1.2. Cabling requirements

LV cables (<1KV) are generally categorized into four; only cables of the same category can be placed together to form a cable bundle, cables of different categories should be separated when cabling and generally not crossed and overlapped; when crossover is unavoidable, they should be crossed at right angles. The cables of different categories need to be spaced at a certain distance from each other. For cable lengths of less than 30m, the allowable minimum spacing is shown in the diagram below. When the length of the parallel cable runs increases, the spacing should be increased appropriately. In addition to maintaining spacing, shielding can also be achieved by putting together multiple shields between cables of different categories. To minimize cross-talk, all cables should be routed as close as possible to the (grounded) structural components to which the cabinet is grounded. For example, assembly panels for cabinets or rack components.

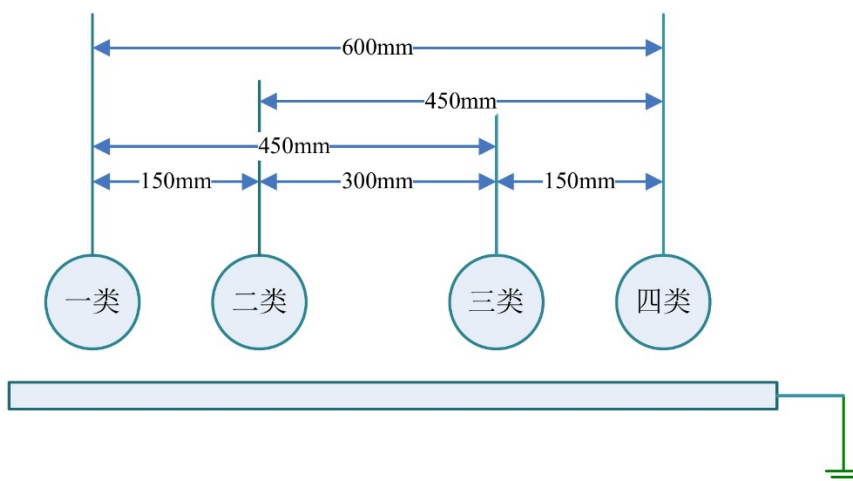

一类	Cat 1
二类	Cat 2
三类	Cat 3
四类	Cat 4

Diagram of cabling requirements for cables of different categories

[Notes] Cat 1: Ethernet, EtherCAT;

Cat 2: Low-speed digital communication signals (RS232, RS485, CAN, etc.) and digital I/O signals

Cat 3: Low voltage AC distribution cables (e.g. PLC 220V AC power cables) or DC power cables  
(e.g. DC 24 power cables for switching power supply outputs)

Cat 4: Input and output cables, welding machine cables, and power cables for power converters

## 5.2. Wiring of the power supply

### 5.2.1. General considerations

#### ■ Selection of power supplies

- Please use a power supply with low noise levels where possible.
- Although there is sufficient noise tolerance for noise overlapping the power supply lines, it is recommended to further reduce noise by using an isolation transformer/isolated power supply.

#### ■ Separation of power supply systems

The cabling on the units, I/O devices and power equipment should each be separated from the system.

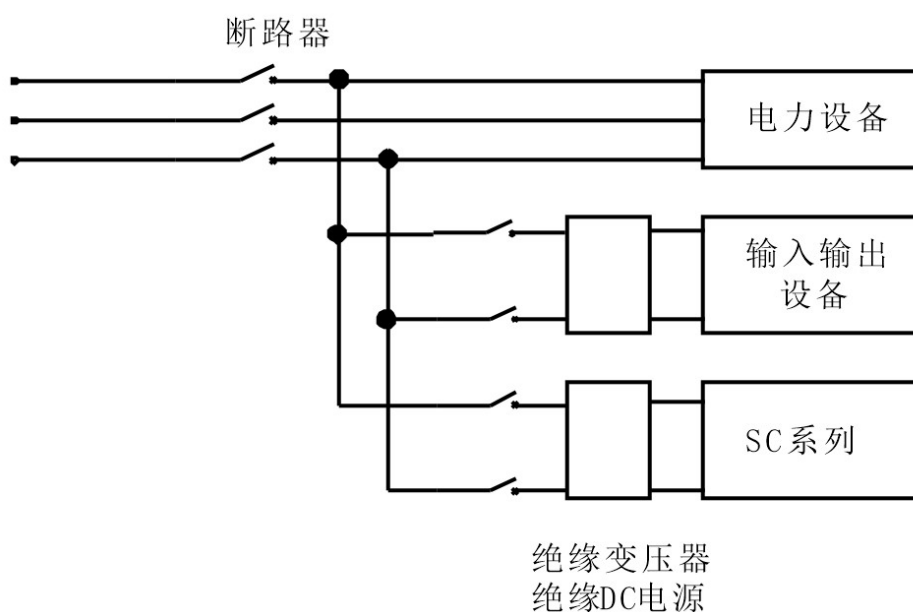

断路器	Circuit breaker
电力设备	Power equipment
输入输出设备	I/O devices
SC系列	SC series
绝缘变压器	Insulating transformer
绝缘 DC 电源	Insulating DC power supplies

#### ■ Power sequence

- Consider the order of power supply and disconnect the power to the controller before disconnecting the power to the input and output.
- If the power for the inputs and outputs is switched off before the power of the controller is switched off, the SC20 Controller may detect a change in the input level and trigger an unexpected sequential action.

## 5.2.2. Power supply for SC20 Controller

### ■ Wiring of the power supply

Unit	Wiring diagram						
SC20 Controller	<table border="1"> <tbody> <tr> <td>褐: +24V</td> <td>Brown: +24V</td> </tr> <tr> <td>蓝: 0V</td> <td>Blue: 0V</td> </tr> <tr> <td>功能性接地</td> <td>Functional grounding</td> </tr> </tbody> </table>	褐: +24V	Brown: +24V	蓝: 0V	Blue: 0V	功能性接地	Functional grounding
褐: +24V	Brown: +24V						
蓝: 0V	Blue: 0V						
功能性接地	Functional grounding						

### ■ Selection of the power supply

- To protect the circuit from abnormal voltages from the power supply line, use an isolated power supply with built-in protection circuitry in the power supply. (Reinforced insulation or double-insulated power supplies)
- Non-isolated types are used in the built-in regulator of the unit.
- Select a power supply with a capacity exceeding that of the unit to be connected. Also, choose a power supply of 24W or more, even in the lowest configuration.

### ■ Supply voltage

- Make sure that the voltage to be connected to the power supply is within the tolerance range.

Rated input voltage	Allowable voltage range	Rated output capacity
24V DC	20.4V - 28.8V DC	Above 24W

### ■ Power supply cable

- Customized supply cable colors and labels are recommended.  
Brown: 24V DC, Blue: 0V, Green: functional ground wire
- To reduce the effect of noise, twist the power cable (twisted wire processing).

## 5.2.3. Grounding

### ■ Use of special grounding

- Be sure to use a Cat D (Cat 3) ground wire with a grounding resistance of 100Ω or less.
- The grounding point should be as close as possible to the SC20 Controller to shorten the distance of

the ground wire.

- When sharing grounding with other equipment, this can sometimes have the opposite effect and therefore a special ground wire must be used.

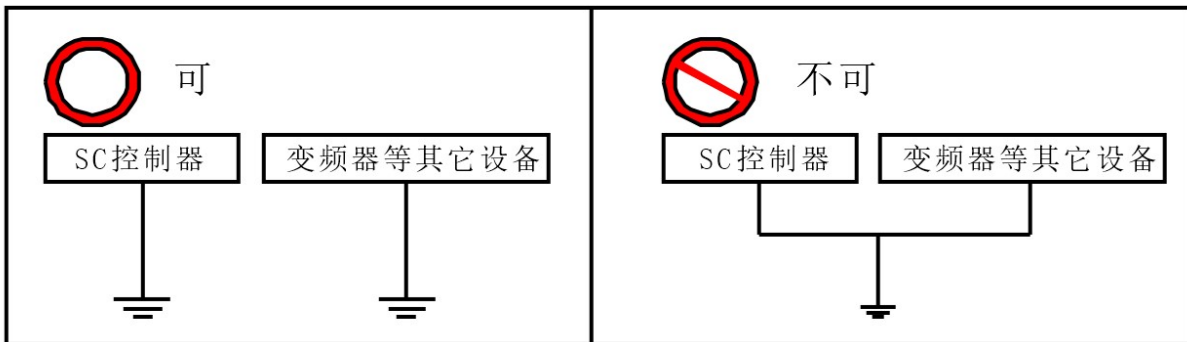

可	Applicable
SC 控制器	SC controller
变频器等其它设备	Other equipment such as inverter
不可	Not Applicable
SC 控制器	SC controller
变频器等其它设备	Other equipment such as inverter

### 5.3. Wiring of the network

Use a Cat 5e shielded LAN cable for network wiring. To prevent disconnection, connect the connector on the cable side securely to the network connector (RJ45 connector) of the main unit.

The length between the nodes should be within 100m and the total length of the communication loop should be within 200m.

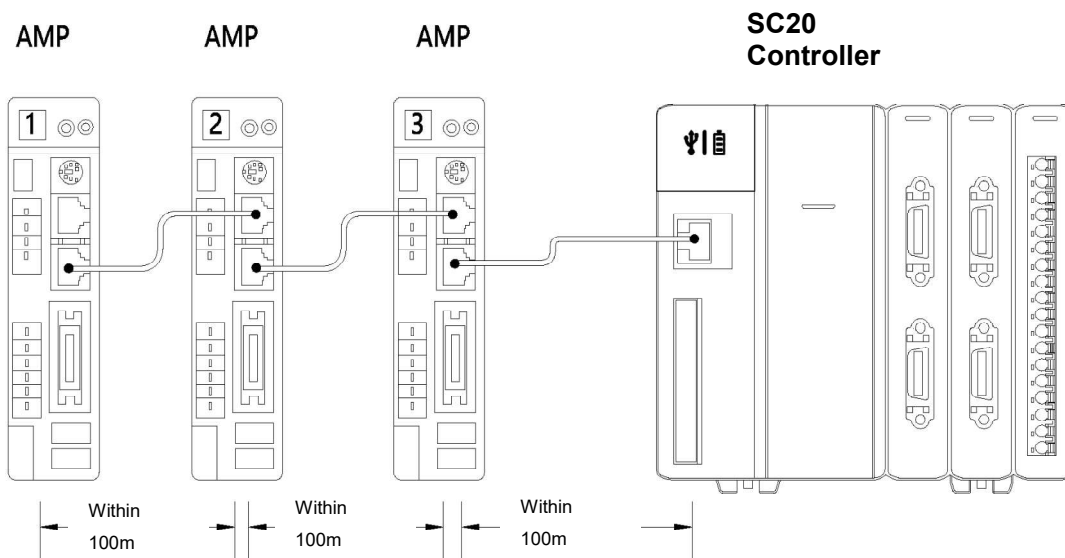

- The LAN (EtherCAT) port connected to the SC20 controller is connected to the communication input port of the Servo Drive, the communication output LAN port of the driver is connected to the next Servo Drive, and so on. The communication connection is of a chain type.

The definition of the network cable is in compliance with the standard 100Base-TX, the same as described in Section 2.2.1 "Software operating environment and applicable cables".

## 5.4. General wiring specifications for I/O modules

### 5.4.1. General considerations for I/Os

#### ■ Location of the wiring

The I/O wiring, as well as the wiring between these and the power cables, should be wired as far away from each other as possible. Do not route or bundle them in the same conduit. The I/O wiring should be at least 100mm away from the power and HV cables.

#### ■ Selection of electrical wires

When wiring the input and output wires, select the diameter of the wire based on the current capacity.

#### ■ Power supply

Turn off the power to the SC20 before wiring. The connection of the SC20 controller to the extension unit should also be carried out with the power off. If the connection is made while the power is ON, a fault or malfunction will occur.

### 5.4.2. Wiring on the input side

#### ■ Connection with photoelectric sensor and proximity sensor

Relay output type

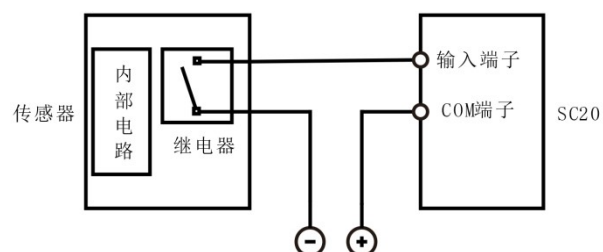

传感器	Sensor
内部电路	Internal circuit
继电器	Relay
输入端子	Input terminal
COM 端子	COM terminal

NPN open collector output type

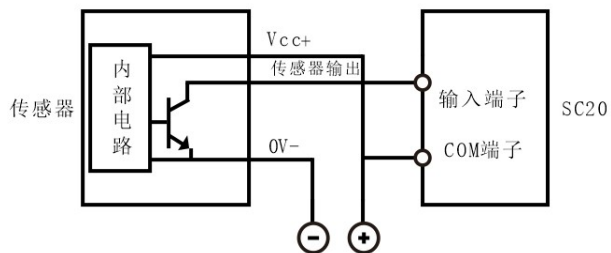

传感器	Sensor
内部电路	Internal circuit
传感器输出	Sensor output
输入端子	Input terminal
COM 端子	COM terminal

Voltage output type

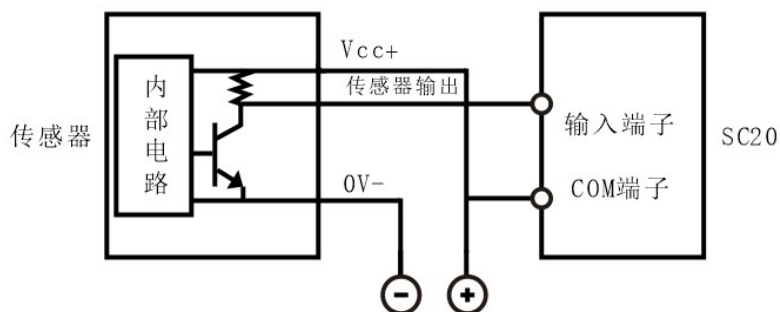

传感器	Sensor
内部电路	Internal circuit
传感器输出	Sensor output
输入端子	Input terminal
COM 端子	COM terminal

Two-wire output type

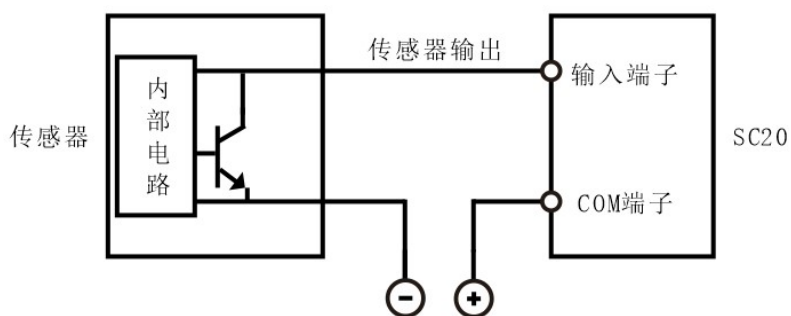

传感器	Sensor
内部电路	Internal circuit
传感器输出	Sensor output
输入端子	Input terminal
COM 端子	COM terminal

### ■ Precautions when using the reed switch with LED

When LEDs are connected in series to the input contacts (e.g. reed switch with LED), apply a voltage greater than the ON voltage to the input terminals of the SC20. Please note in particular when connecting several switches in series.

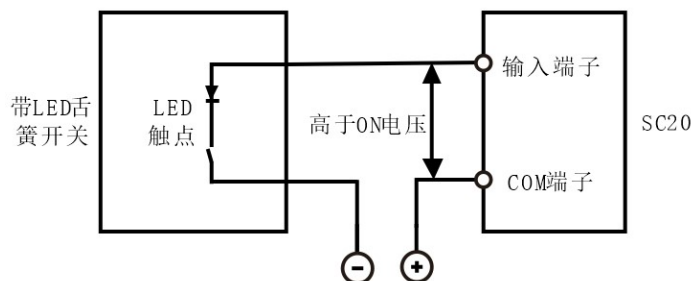

带 LED 舌簧开关	Reed switch with LED
LED 触点	LED contacts
高于 ON 电压	Greater than ON voltage
输入端子	Input terminal
COM 端子	COM terminal

### ■ Precautions when using reed switches with LEDs

When using a two-wire photoelectric sensor or proximity sensor, if the input current to the SC20 cannot be cut off due to leakage current, connect the bleeder resistor as shown below.

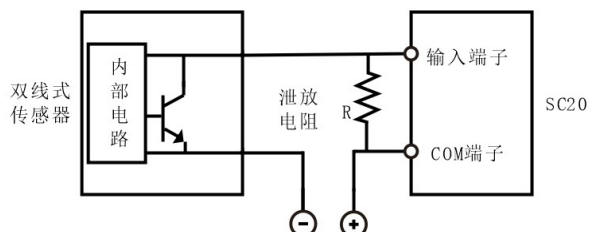

双线式传感器	Two-wire sensor
内部电路	Internal circuit
泄放电阻	Bleeder resistor
输入端子	Input terminal
COM 端子	COM terminal

### ■ Precautions when using the limit switch with LED

When using a limit switch with LED, if the input current to the SC20 cannot be cut off due to leakage current, connect the bleeder resistor as shown below.

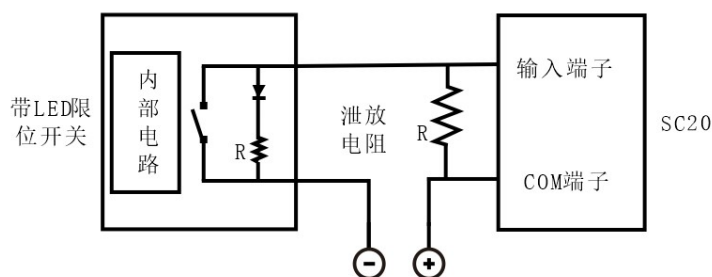

带LED限位开关	Limit switch with LED
内部电路	Internal circuit
泄放电阻	Bleeder resistor
输入端子	Input terminal
COM 端子	COM terminal

### 5.4.3. Axis-controlled high-speed counter input wiring

#### ■ Part 1. In case of line drivers with encoder input

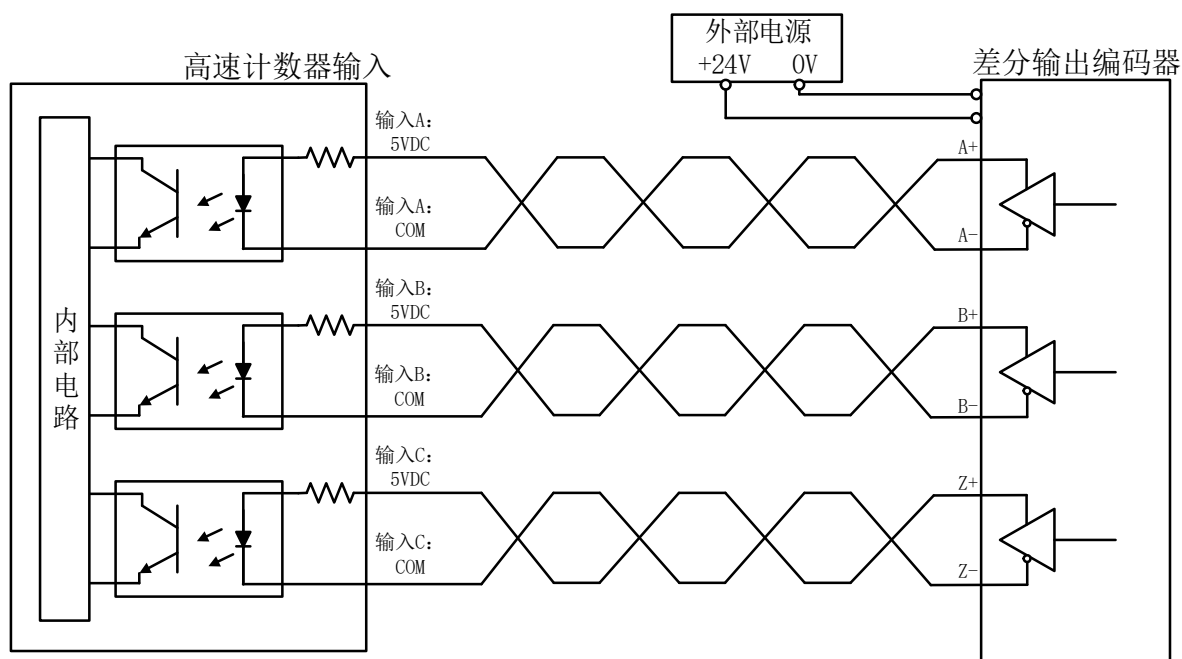

内部电路	Internal circuit
高速计数器输入	High-speed counter input
输入 A: 5VDC	Input A: 5V DC
输入 A:COM	Input A: COM
输入 B:5VDC	Input B: 5V DC
输入 B:COM	Input B: COM
输入 C:5VDC	Input C: 5V DC
输入 C:COM	Input C: COM
外部电源	External power supply
差分输出编码器	Differential output encoder

■ Part 1. Transistor with encoder input - In case of open collector type

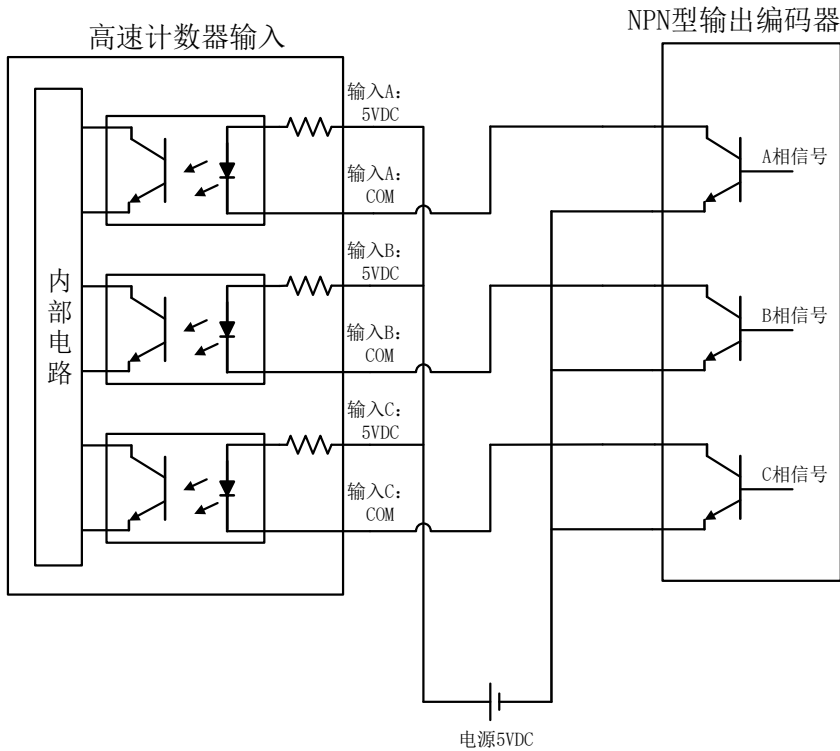

内部电路	Internal circuit
高速计数器输入	High-speed counter input
输入 A: 5VDC	Input A: 5V DC
输入 A:COM	Input A: COM
输入 B:5VDC	Input B: 5V DC
输入 B:COM	Input B: COM
输入 C:5VDC	Input C: 5V DC
输入 C:COM	Input C: COM
NPN 型输出编码器	NPN type output encoder
A 相信号	Phase A signal
B 相信号	Phase B signal
C 相信号	Phase C signal
电源 5VDC	5V DC power supply

■ Part 1. Sensor inputs

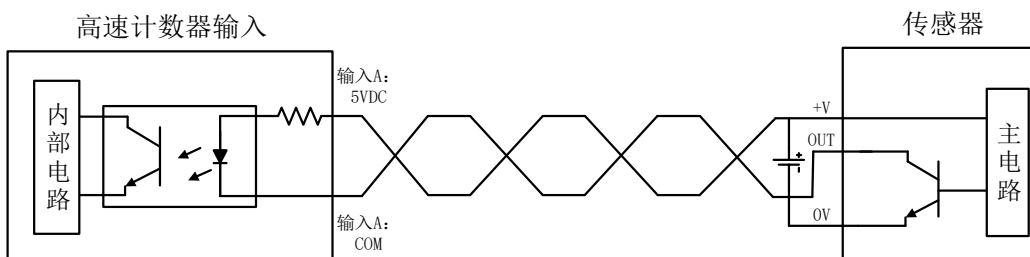

内部电路	Internal circuit
高速计数器输入	High-speed counter input
输入 A: 5VDC	Input A: 5VDC

输入 A:COM	Input A: COM
传感器	Sensor
主电路	Main circuit

■ Part 2. High-speed pulse command output (differential output)

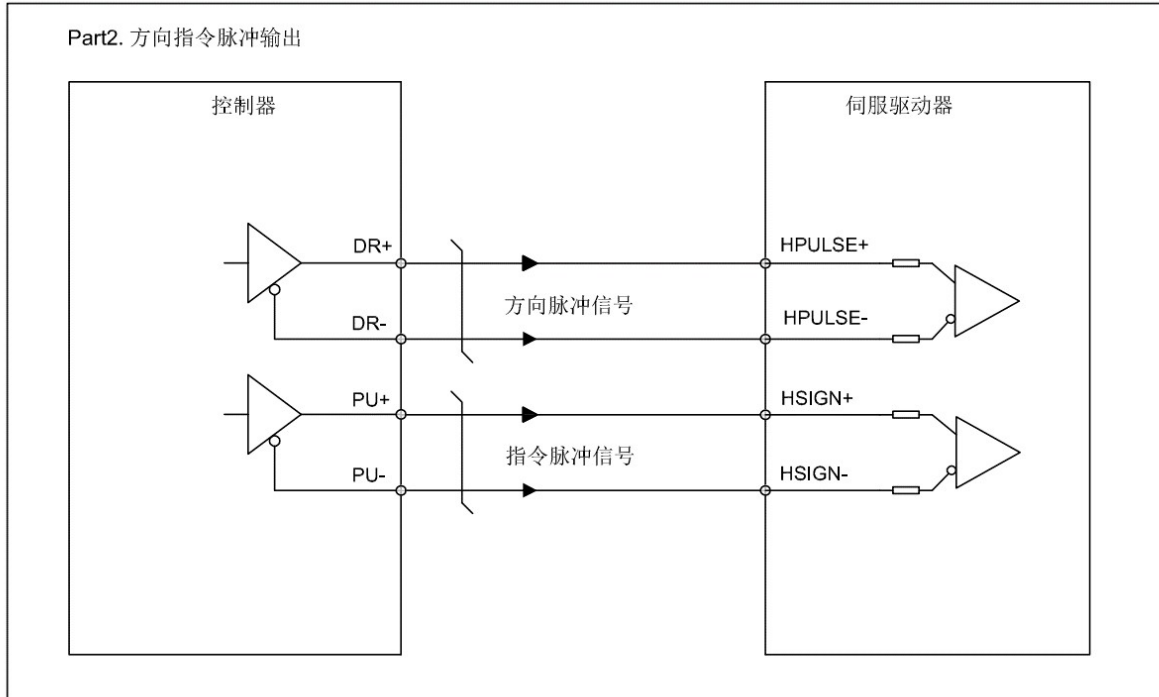

Part2.方向指令脉冲输出	Part 2. Directional command pulse output
控制器	Controller
方向脉冲信号	Directional pulse signal
指令脉冲信号	Command pulse signal
伺服驱动器	Servo driver

5.4.4. Wiring on the output side

■ Protection circuit for inductive loads

For inductive loads, install a protection circuit in parallel with the load.

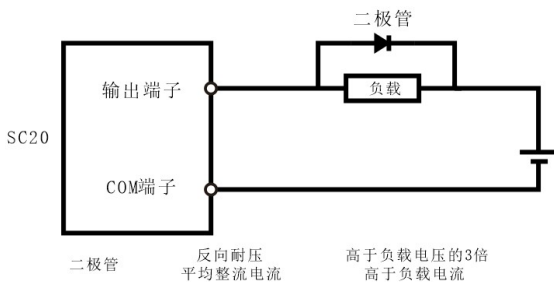

输出端子	Output terminal
COM 端子	COM terminal

二极管	Diode
负载	Load
二极管	Diode
反向耐压	Reverse withstand voltage
平均整流电流	Average rectified current
高于负载电压的 3 倍	3 times greater than the load voltage
高于负载电流	Greater than load current

### ■ Precautions when using capacitive loads

When connecting a load with a high impulse current, to minimize its effect, install the following protection circuit.

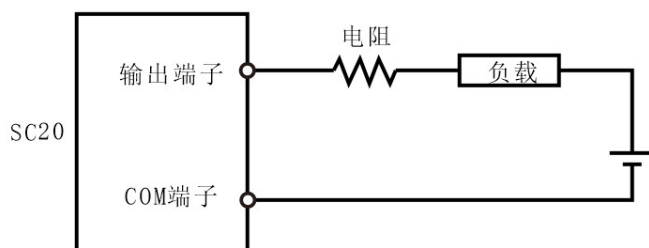

输出端子	Output terminal
COM 端子	COM terminal
电阻	Resistance
负载	Load

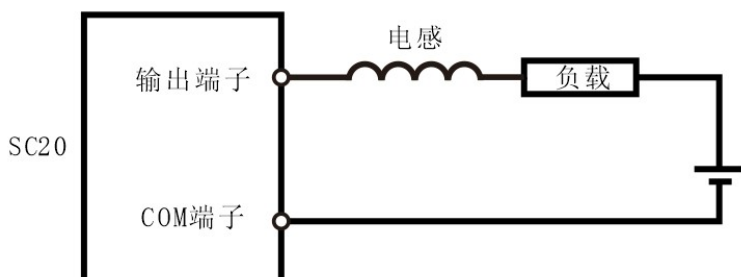

输出端子	Output terminal
COM 端子	COM terminal
电感	Inductance
负载	Load

**5.4.5. RS485 communication terminal resistor wiring**

**■ Topology structure**

The RS485 bus connection topology is shown in the diagram below. The RS485 bus is recommended to be connected with a shielded twisted pair, while 485+ and 485- are connected with twisted pair; only 120 Ω termination matched resistors are connected at each end of the bus to prevent signal reflection, the termination resistors are built into the 485 terminals of the controller and no external connection is required; the reference grounds of all nodes 485 signals are connected together; a maximum of 128 nodes are connected and the distance between each node branch is less than 3M.

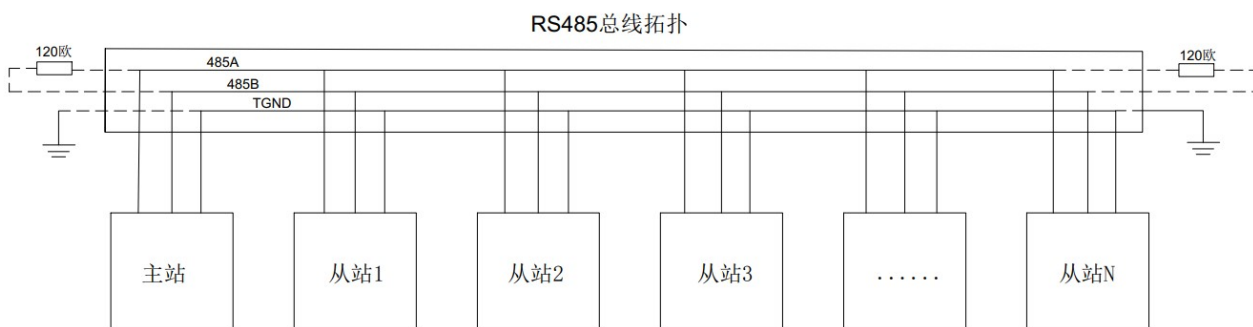

RS485 总线拓扑	RS485 bus topology
120 欧	120 Ohms
主站	Master
从站 1	Slave 1
从站 2	Slave 2
从站 3	Slave 3
从站 N	Slave N

When there are a large number of nodes, the 485 bus must be daisy-chained. If a branch line connection is required, the shorter the branch length from the bus to the node the better, less than 3m is recommended. The star connection is strongly discouraged.

RS485总线拓扑



RS485 总线拓扑	RS485 bus topology
主站	Master
从站 1	Slave 1

从站 2	Slave 2
从站 3	Slave 3
从站 N	Slave N

■ Terminal wiring method

Please check that the field 485 bus contains three cables connected to the 485A, 485B and TGND terminals and that the terminals are not reversed or connected incorrectly. If shielded cables are used, it is particularly important that the shield is also connected to the TGND terminal. At any node or midway point, the shield must not be connected anywhere other than to the TGND of the node (including the field enclosure, equipment ground terminal, etc.).

Due to the attenuation effect of the cable, it is recommended to use AGW26 or thicker cable for all connection lengths greater than 3m. It is always recommended to use twisted pair cables for the 485A and 485B connection cables.

A terminating resistor at one end of the bus is already built into the terminal and requires no additional external connection.

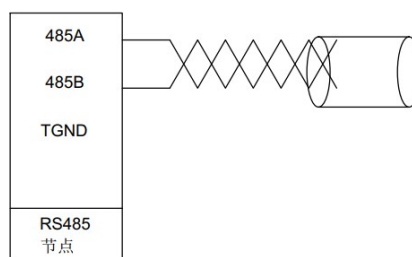
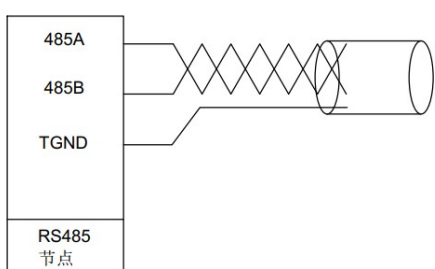

RS485 节点

RS485 nodes

Diagram of TGND terminals available on site

Diagram of TGND terminals not available on site

5.4.6. CAN communication terminal resistor wiring

■ Topology structure

The CAN bus connection topology is shown below. It is recommended to use a shielded twisted pair connection with two 120 Ω termination matching resistors at each end of the bus to prevent signal reflection. The shield is generally reliably grounded using a single point.

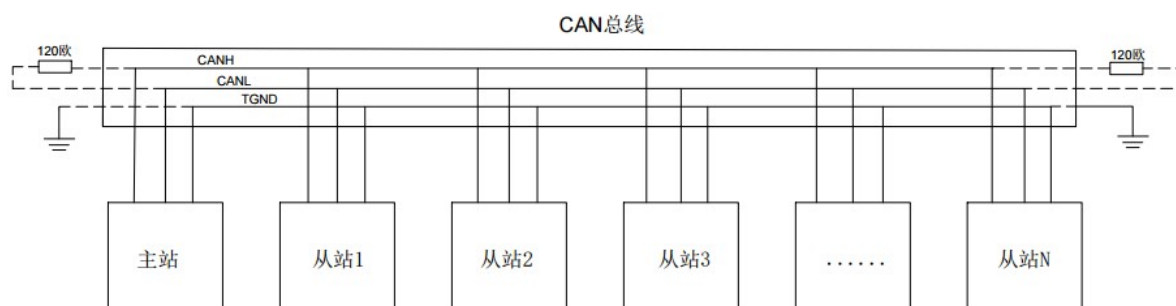

CAN 总线	CAN bus
120 欧	120 Ohms
主站	Master
从站 1	Slave 1
从站 2	Slave 2
从站 3	Slave 3
从站 N	Slave N

### Terminal wiring method

It is recommended to use a shielded twisted pair connection with two 120 Ω termination matching resistors at each end of the bus to prevent signal reflection. The shield is generally reliably grounded using a single point. Do not bundle the cable with AC power cables, HV cables etc. when fixing it to avoid interference with the communication signal.

A terminating resistor at one end of the bus is already built into the terminal and requires no additional external connection.

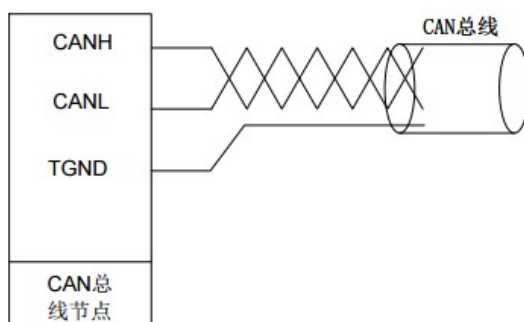

CAN bus  
CAN bus nodes

Diagram of the wiring terminals

### 5.4.7. Instructions for DI input wiring

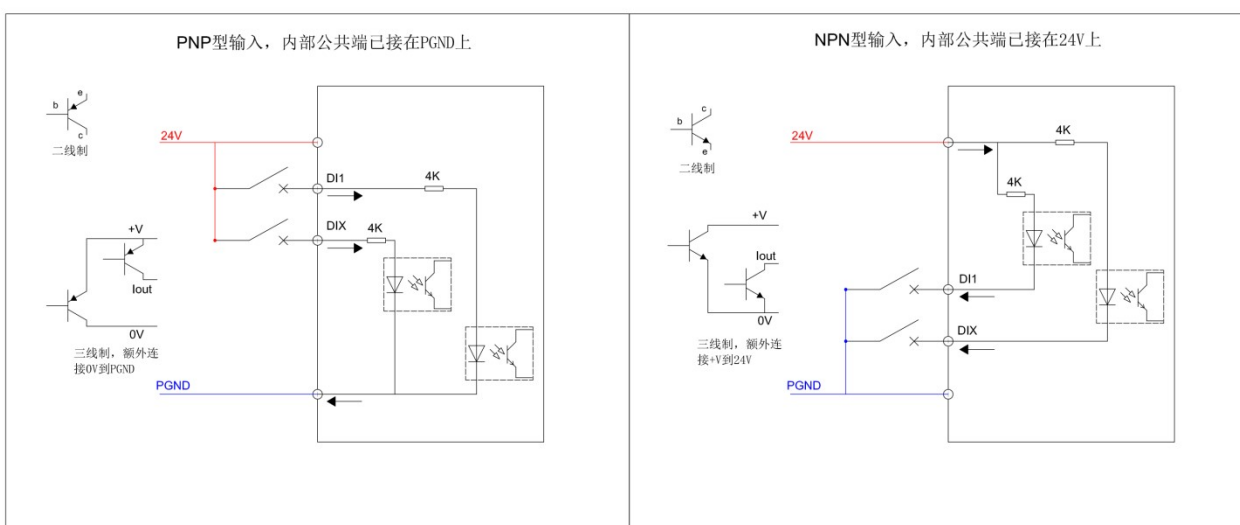

PNP 型输入，内部公共端已接在 PGND 上	PNP type input, with internal common already connected to PGND
二线制	Two-wire system
三线制，额外连接 OV 到 PGND	Three-wire system, with OV additionally connected to PGND
NPN 型输入，内部公共端已接在 24V 上	NPN type input, with internal common-terminal already connected to 24V
二线制	Two-wire system
三线制，额外连接 +V 到 24V	Three-wire system, with +V additionally connected to 24V

Knowledge elements:

1. To determine which type of input is supported, simply determine whether the common terminal of the external device is connected at 24V (PNP type) or 0V (NPN type). Some of them support both types, where the common terminal of the internal circuit is not connected directly to the power supply, but a COM port is provided for the user to customize the connection to 24V or 0V, so that the common terminal of the external device can then also be changed. The internal photocoupler must of course be bidirectional at this point.

2. Source input corresponds to PNP input; sinking input corresponds to NPN input.

PNP type input wiring, external device common terminal connected to 24V, and signal output terminal connected to DIX. In the three-wire system, the signal output lout is connected to DIX and the +V and 0V terminals are connected to both ends of the 24V supply, i.e. 24V and PGND.

For NPN type input wiring, the common terminal of the external device is connected to PGND and the signal output to DIX. In the three-wire system, the signal output lout is connected to DIX and the remaining two wires are connected to both ends of the power supply.

## 5.5. Module Terminal Signal Arrangement and Cable Production

### 5.5.1. Cable production

The axis-controlled high-speed counter board uses DB20 connectors (to be customized) and the LAN port uses RJ45 (8P8C) plugs. All other I/O terminals are wired using PUSH IN inline wiring, which does not require a customized cluster socket.

#### ■ Diameter and specification of connection cables

Item	Reference data
Power supply wiring ( $mm^2$ )	0.5-1.5
I/O module ( $mm^2$ )	0.2-1.5
In-line cable stripping length (mm)	8-9

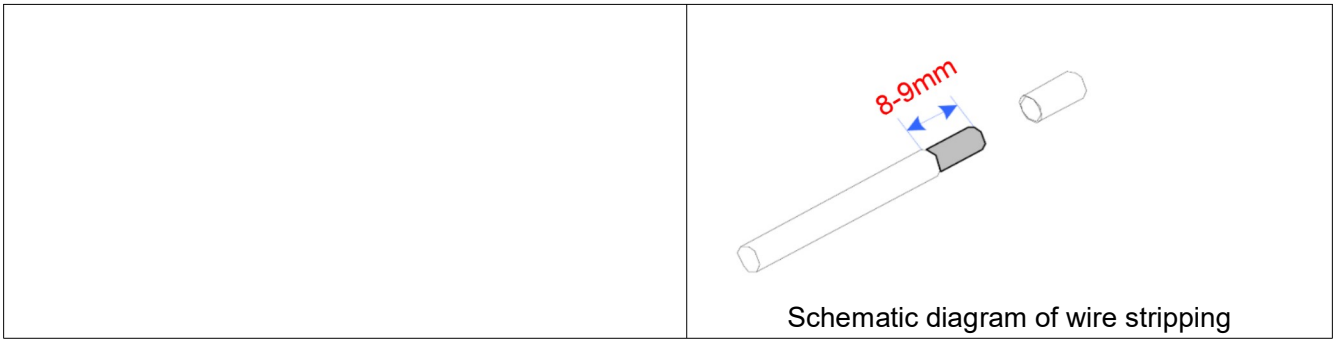

**5.5.2. Signal arrangement and definition of terminals for serial ports and power interfaces**

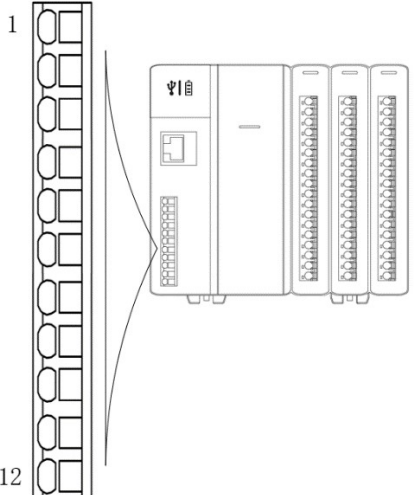
Diagram of the terminal arrangement	No.	Name	Function
	1	485A	RS485 communication +
	2	485B	RS485 communication -
	3	TGND	Power reference ground
	4	RX	RS232 receiver
	5	TX	RS232 transmitter
	6	TGND	Power reference ground
	7	CANH	CAN+
	8	CANL	CAN-
	9	TGND	Power reference ground
	10	24V	Power input 24V
	11	GND	Power input ground
	12	PE	Ground

Wiring references:

[RS485 communication field wiring and termination resistor wiring](#)

[CAN communication field wiring and termination resistor wiring](#)

### 5.5.3. Signal arrangement and definition of analog-digital hybrid I/O board terminals

Diagram of the terminal arrangement	No.	Name	Function
	1	AI1	Analog input 1
	2	AI2	Analog input 2
	3	AGND	Analog ground
	4	DI1	Digital input
	5	DI2	Digital input
	6	DI3	Digital input
	7	DI4	Digital input
	8	HDI5	High-speed digital input
	9	HDI6	High-speed digital input
	10	HDI7	High-speed digital input
	11	HDI8	High-speed digital input
	12	COM+	Common terminal
	13	DO1	Digital output
	14	DO2	Digital output
	15	DO3	Digital output
	16	DO4	Digital output
	17	24V	Supplementary power input
	18	PGND	Supplementary power ground

## ■ Peripheral wiring and internal module circuitry

The SC20 Controller body module SLT20 allows the 2-channel AI to share a common terminal and 0-10V voltage input; 8-channel DI only support NPN type input, of which 4-channel high-speed DI supports 10KHz. The 4-channel DO is of NPN type input. For NPN type and PNP type input wiring, please refer to the "[Instructions for DI input wiring](#)".

For the module peripheral wiring, connect as follows:

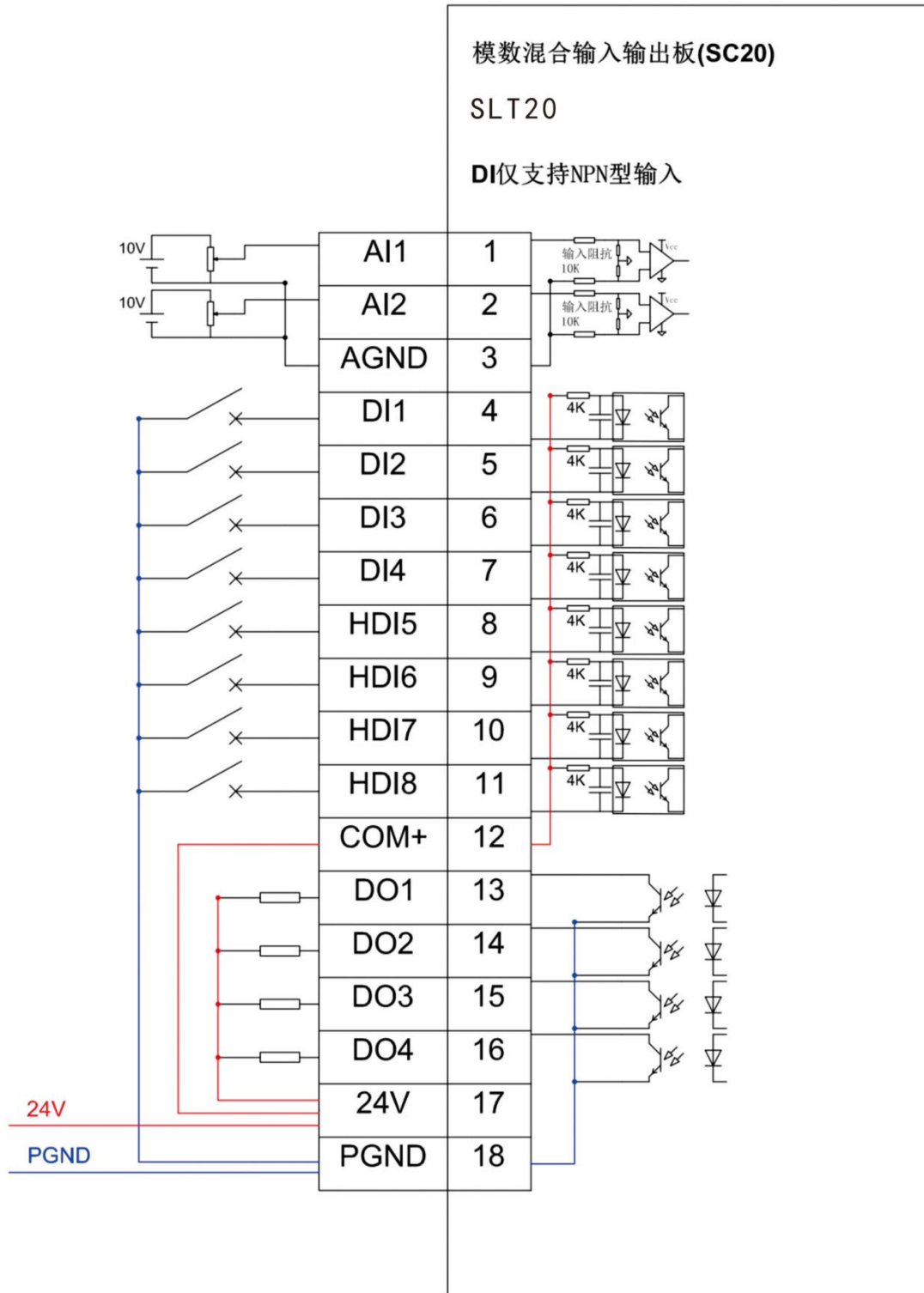

模数混合输入输出板(SC20)	Analog-digital hybrid I/O board (SC20)
DI 仅支持 NPN 型输入	DI only supports NPN type inputs
输入阻抗	Input impedance

### 5.5.4. Arrangement and definition of signals of locally optional general I/O board terminals

Diagram of the terminal arrangement	No.	Name	Function	Remarks
	1	DI1	Digital input	Sinking input, active low
	2	DI2	Digital input	Sinking input, active low
	3	DI3	Digital input	Sinking input, active low
	4	DI4	Digital input	Sinking input, active low
	5	DI5	Digital input	Sinking input, active low
	6	DI6	Digital input	Sinking input, active low
	7	DI7	Digital input	Sinking input, active low
	8	DI8	Digital input	Sinking input, active low
	9	DI9	Digital input	Sinking input, active low
	10	DI10	Digital input	Sinking input, active low
	11	DI11	Digital input	Sinking input, active low
	12	DI12	Digital input	Sinking input, active low
	13	DO1	Digital output	Sinking output, active low
	14	DO2	Digital output	Sinking output, active low
	15	DO3	Digital output	Sinking output, active low
	16	DO4	Digital output	Sinking output, active low
	17	24V	Supplementary power input	—
	18	PGND	Supplementary power ground	—

■ Peripheral wiring and internal module circuitry

The module X12Y4 only supports NPN type inputs. Three-wire or two-wire system? And NPN or PNP types? Please refer to the "[Instructions for DI input wiring](#)".

For module wiring, please connect as follows:

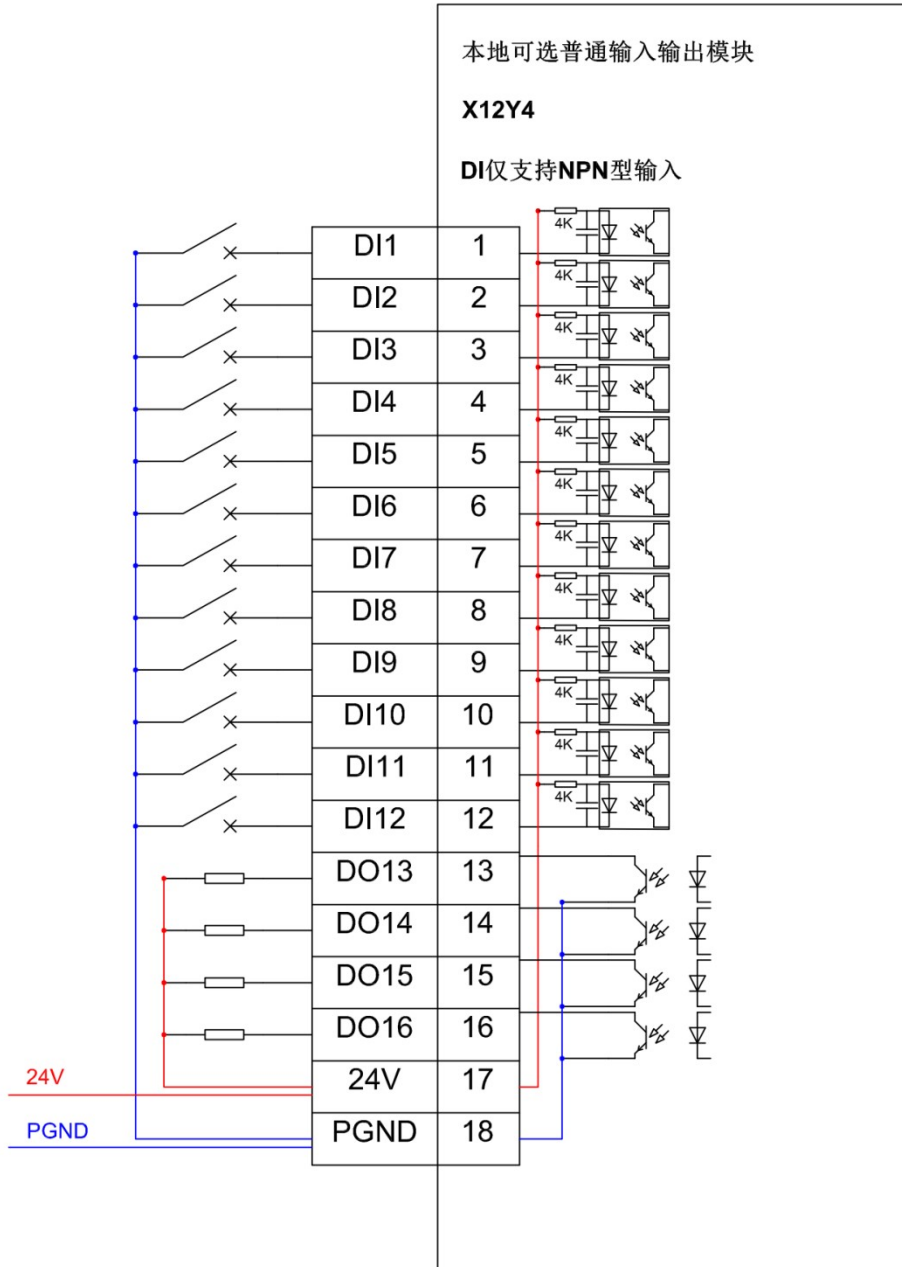

本地可选普通输入输出模块	Locally optional general I/O modules
DI 仅支持 NPN 型输入	DI only supports NPN type inputs

### 5.5.5. Arrangement and definition of signals for locally optional axis-controlled high-speed counter board terminals

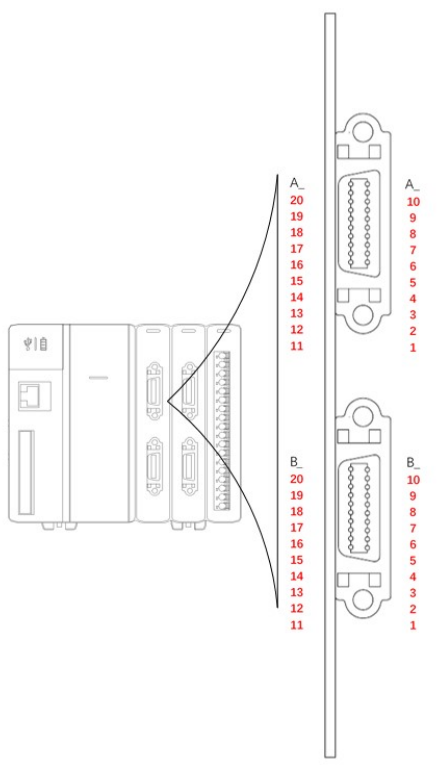
Diagram of the terminal arrangement	NO.		Name	Purpose
	A_	B_		
	1	1	ECA1+	Encoder A
	2	2	ECA1-	Encoder A
	3	3	ECB1+	Encoder B
	4	4	ECB1-	Encoder B
	5	5	ECZ1+	Encoder Z
	6	6	ECZ1-	Encoder Z
	7	7	OPC	Reserved high-speed DI+
	8	8	PULS	Reserved high-speed DI-
	9	9	SRV_COIN	Servo positioning completion DI
	10	10	ALARM	Servo alarm DI
	11	11	+5V_ENC	Encoder power supply
	12	12	EGND	Encoder reference ground
	13	13	DR+	Direction of command
	14	14	DR-	Direction of command
	15	15	PU+	Command pulse
	16	16	PU-	Command pulse
	17	17	24V	Power output
	18	18	GND_24V	Reference ground
	19	19	SRV_ON	Enable servo DO
	20	20	CLEAR	Clear servo alarm DO

The axis-controlled high-speed counter module uses DB20 plugs. The pins of the plugs are customized in accordance with the "Arrangement and definition of signals for locally optional axis-controlled high-speed counter board terminals".

Description of the DB20 connector assembly

Item	Model
DB20 male connector 	SM-SCSI-20P

## ■ Peripheral wiring and internal module circuitry

The terminals are wired in 3 parts, of which the wiring for Part 1 and Part 2 can be found below, and the last part is for the servo system signals. For signal functions, please refer to the "[Arrangement and definition of signals for locally optional axis-controlled high-speed counter board terminals](#)".

Servo signal DI inputs: SRV\_COIN (servo positioning completion DI) and ALARM (servo alarm DI) support only the NPN type inputs.

Servo signal DO output: SRV\_ON (enable servo DO), CLEAR (clear servo alarm DO) is of the NPN type output.

A set of high-speed DI inputs, OPC and PULS, are reserved for user customization, and the wiring supports NPN and PNP inputs. Only NPN type inputs are illustrated below. For the ways of NPN type and PNP type inputs, please refer to the "[Instructions for DI input wiring](#)".

Part 1. Encoders: Refer to the "[Axis-controlled high-speed counter input wiring](#)".

Part 2. Directional command pulse output: The signal is a 5V signal, so do not connect to a 24V system. Please refer to the "[Axis-controlled high-speed counter input wiring](#)".

**Note:** There are 5V and 24V systems coexisting in the terminals, it is necessary to pay attention to the terminal serial number to prevent 24V from being connected to the 5V system, which may cause serious consequences.

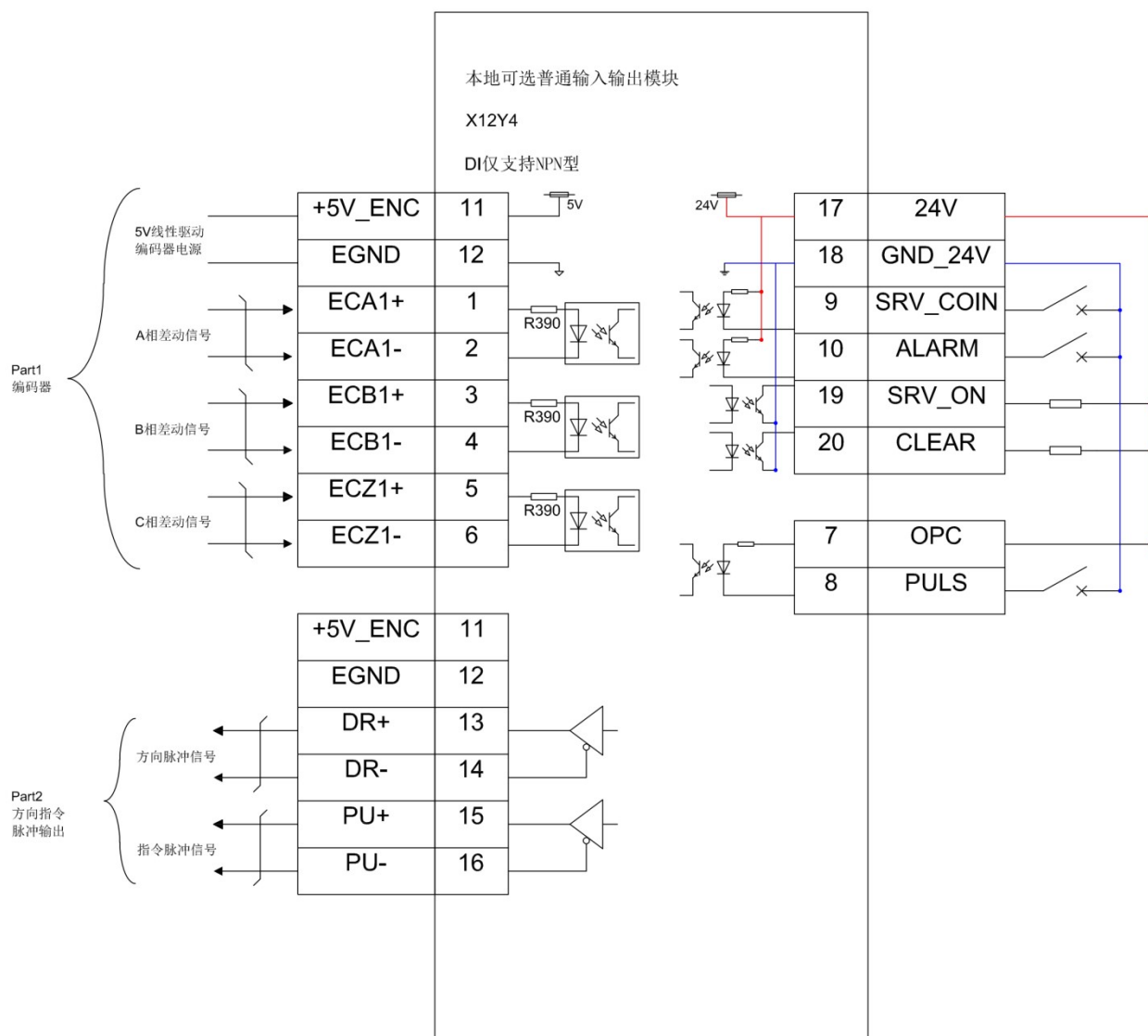

本地可选普通输入输出模块	Locally optional general I/O modules
DI 仅支持 NPN 型	DI only supports NPN type
编码器	Encoder
5V 线性驱动编码器电源	5V linear drive encoder power supply
A 相差动信号	A-phase differential signals
B 相差动信号	B-phase differential signals
C 相差动信号	C-phase differential signals
方向指令脉冲输出	Directional command pulse output
方向脉冲信号	Directional pulse signal
指令脉冲信号	Command pulse signal

### 5.5.6. Arrangement and definition of the signals of the local extension digital input board terminals

Diagram of the terminal arrangement	No.	Name	Function	Remarks
	1	DI1	Digital input	
	2	DI2	Digital input	
	3	DI3	Digital input	
	4	DI4	Digital input	
	5	DI5	Digital input	
	6	DI6	Digital input	
	7	DI7	Digital input	
	8	DI8	Digital input	
	9	DI9	Digital input	
	10	DI10	Digital input	
	11	DI11	Digital input	
	12	DI12	Digital input	
	13	DI13	Digital input	
	14	DI14	Digital input	
	15	DI15	Digital input	
	16	DI16	Digital input	
	17	COM	Common terminal	—
	18	NC	Empty pin	—

SL-X16A01 only supports low level input, and COM is connected to 24V.

SL-X16C01 only supports low/high level inputs, and COM is connected to 24V or 0V.

■ Peripheral wiring and internal module circuitry

The DI input type of the module X16 supports both PNP and NPN inputs; however, **it should be noted that all the inputs need to be of one type** and that the internal common of each input is connected to COM when using, so it is not possible to use both PNP and NPN inputs. Refer to the "[Instructions for DI input wiring](#)" for the two DI input types!

Note: **All input types must be of one type!!!**

**For NPN type inputs (sinking type signal inputs), please wire as follows:**

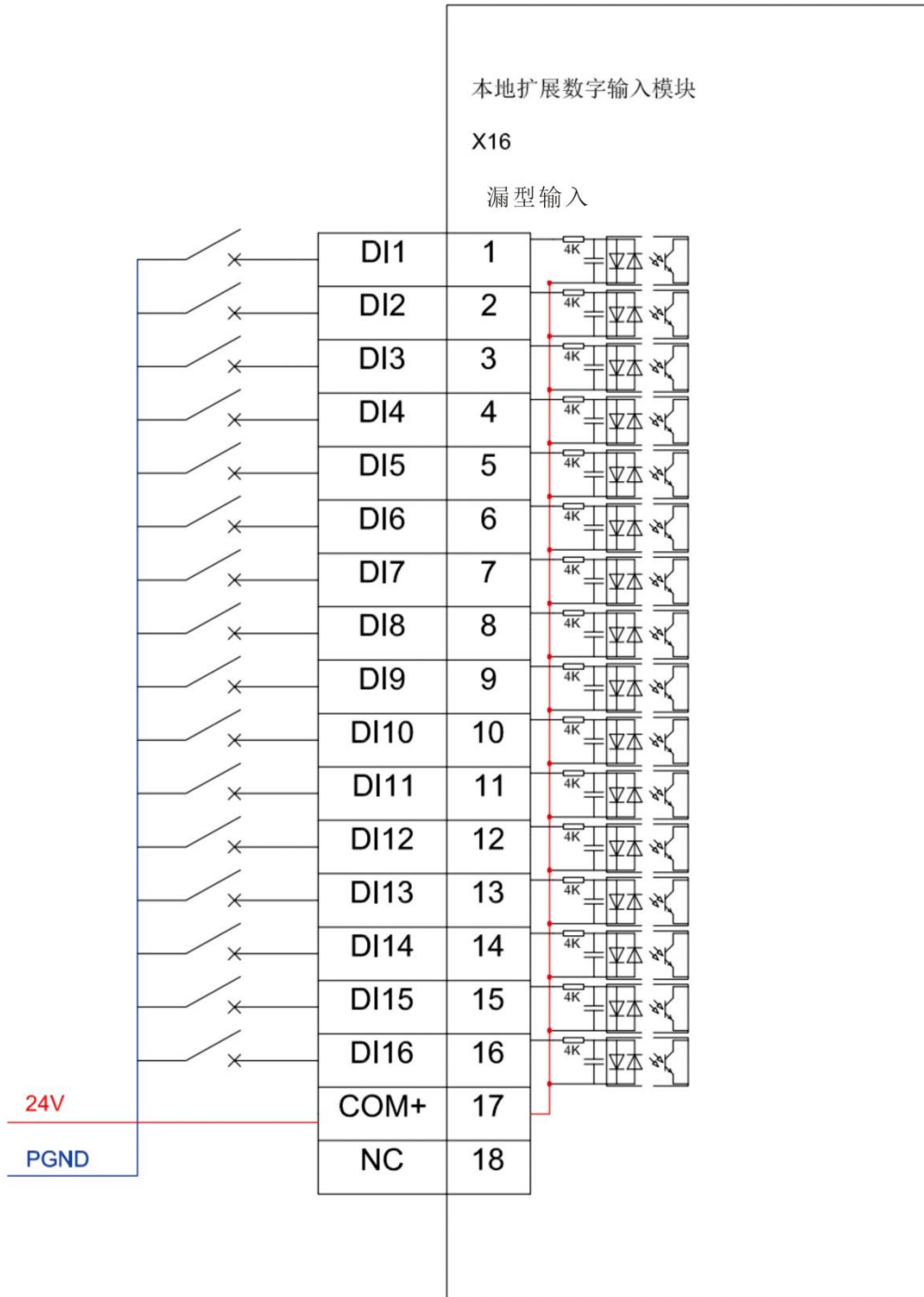

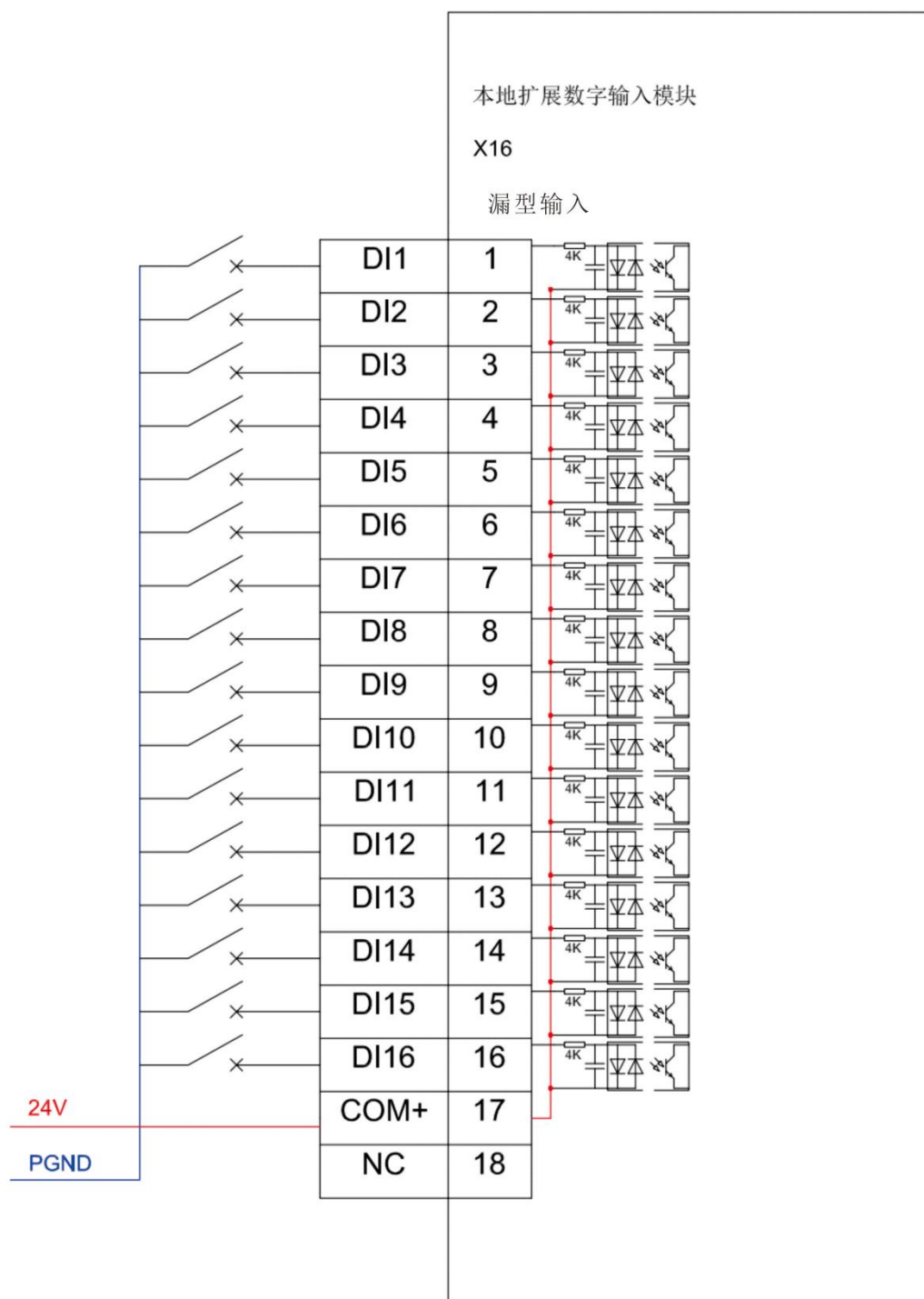

本地扩展数字输入模块	Local extension digital input modules
漏型输入	Sinking input

For PNP type inputs (source type signal inputs), please wire as follows:

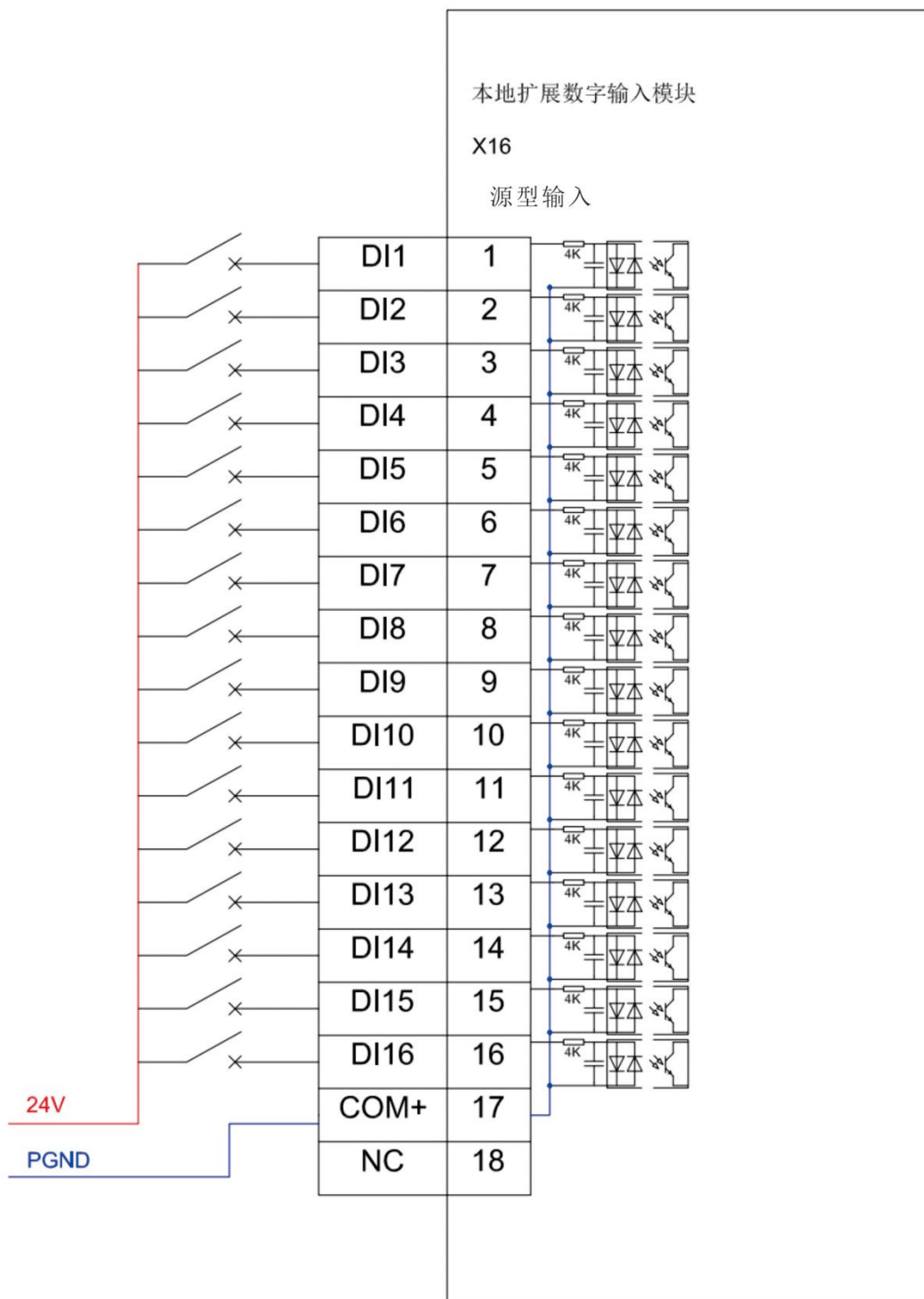

本地扩展数字输入模块	Local extension digital input modules
源型输入	Source-type input

### 5.5.7. Arrangement and definition of the signals of the local extension digital output terminals

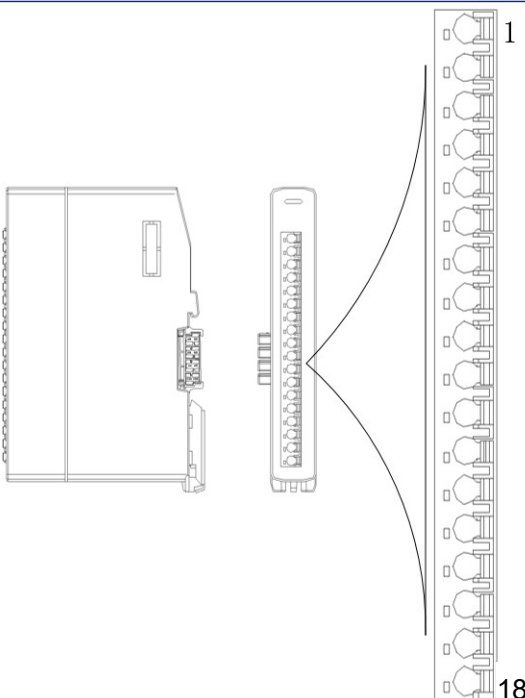
Diagram of the terminal arrangement	No.	Name	Function	Remarks
	1	DO1	Digital output	Sinking output, active low
	2	DO2	Digital output	Sinking output, active low
	3	DO3	Digital output	Sinking output, active low
	4	DO4	Digital output	Sinking output, active low
	5	DO5	Digital output	Sinking output, active low
	6	DO6	Digital output	Sinking output, active low
	7	DO7	Digital output	Sinking output, active low
	8	DO8	Digital output	Sinking output, active low
	9	DO9	Digital output	Sinking output, active low
	10	DO10	Digital output	Sinking output, active low
	11	DO11	Digital output	Sinking output, active low
	12	DO12	Digital output	Sinking output, active low
	13	DO13	Digital output	Sinking output, active low
	14	DO14	Digital output	Sinking output, active low
	15	DO15	Digital output	Sinking output, active low
	16	DO16	Digital output	Sinking output, active low
	17	24V	IO supplementary power	—
	18	PGND	IO reference ground	—

■ Peripheral wiring and internal module circuitry

The DO output type of module Y16 is of a sinking type (NPN type output).

When DO is a general load, be wired as follows:

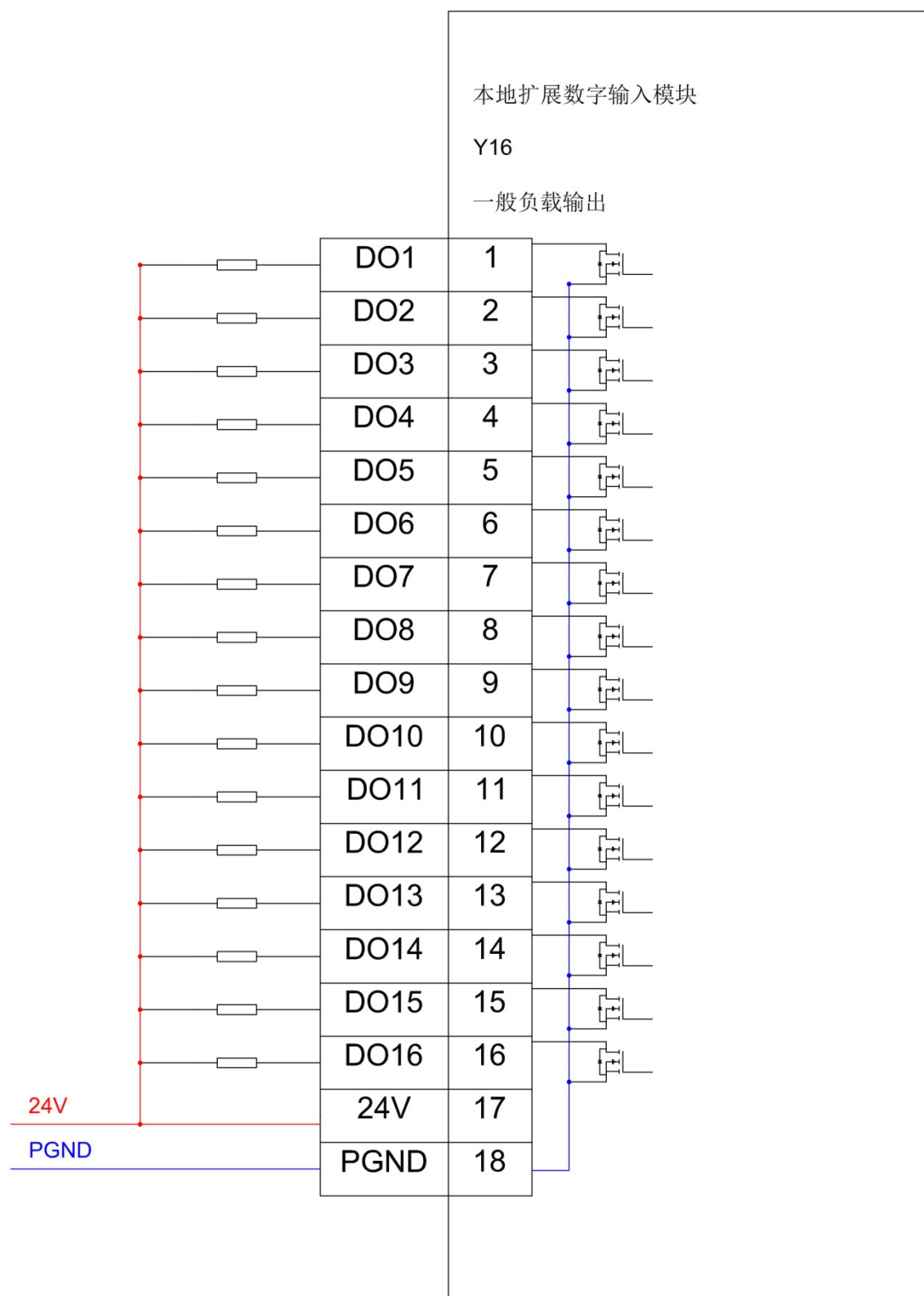

本地扩展数字输入模块	Local extension digital input modules
一般负载输出	General load output

### 5.5.8. Arrangement and definition of the signals of the local extension digital I/O terminals

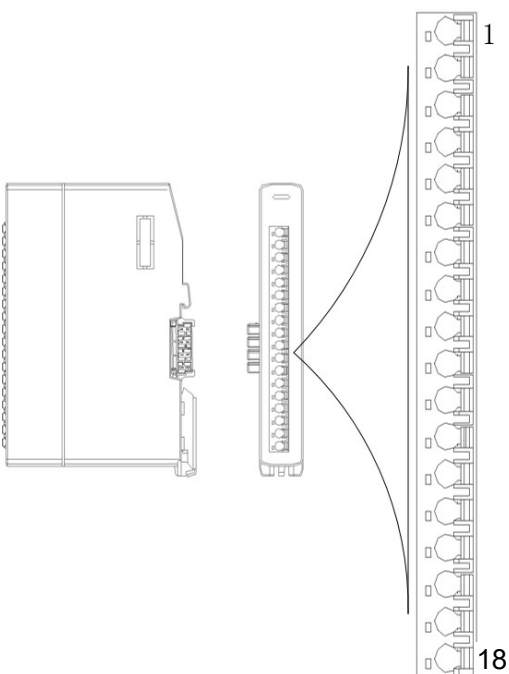
Diagram of the terminal arrangement	No.	Name	Function	Remarks
	1	DO1	Digital output	Sinking output, active low
	2	DO2	Digital output	Sinking output, active low
	3	DO3	Digital output	Sinking output, active low
	4	DO4	Digital output	Sinking output, active low
	5	DO5	Digital output	Sinking output, active low
	6	DO6	Digital output	Sinking output, active low
	7	DO7	Digital output	Sinking output, active low
	8	DO8	Digital output	Sinking output, active low
	9	DI1	Digital input	Sinking input, active low
	10	DI2	Digital input	Sinking input, active low
	11	DI3	Digital input	Sinking input, active low
	12	DI4	Digital input	Sinking input, active low
	13	DI5	Digital input	Sinking input, active low
	14	DI6	Digital input	Sinking input, active low
	15	DI7	Digital input	Sinking input, active low
	16	DI8	Digital input	Sinking input, active low
	17	24V	IO supplementary power	—
	18	PGND	IO reference ground	—

#### ■ Peripheral wiring and internal module circuitry

The I/O type of the module X8Y8 is of a sinking type (active low).

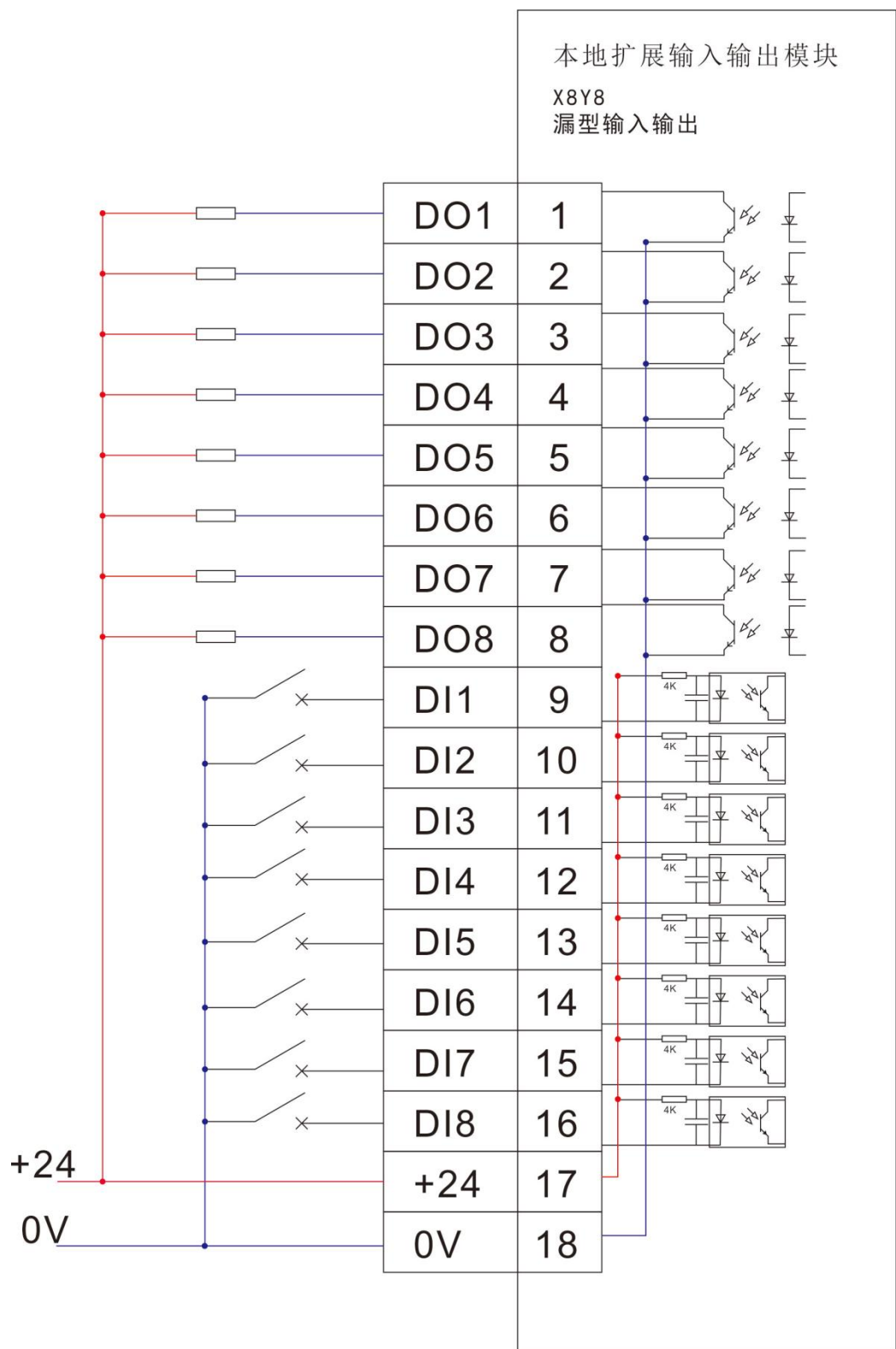

本地扩展输入输出模块	I/O modules for local extension
漏型输入输出	Sinking I/O

### 5.5.9. Arrangement and definition of the signals of the local extension analog I/O board terminals

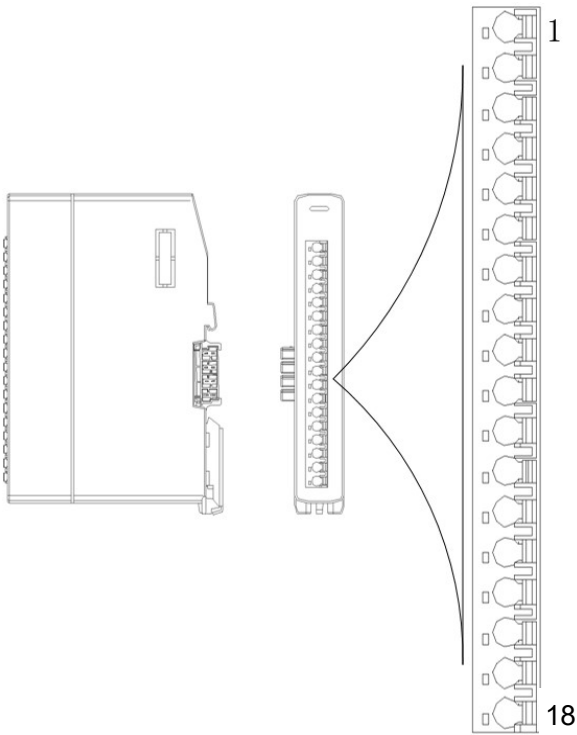
Diagram of the terminal arrangement	No.	Name	Function
	1	AI1+	Analog input positive (+)
	2	AI1-	Analog input negative (-)
	3	AI2+	Analog input positive (+)
	4	AI2-	Analog input negative (-)
	5	AI3+	Analog input positive (+)
	6	AI3-	Analog input negative (-)
	7	AI4+	Analog input positive (+)
	8	AI4-	Analog input negative (-)
	9	AGND	Analog ground
	10	AO1+	Analog output positive (+)
	11	AO1-	Analog output negative (-)
	12	AO2+	Analog output positive (+)
	13	AO2-	Analog output negative (-)
	14	AGND	Analog ground
	15	NC	Empty pin
	16	NC	Empty pin
	17	24V	IO supplementary power
	18	PGND	IO reference ground

Note: This analog module, powered by 24VDC via Pin17 and Pin18, supplies part of the power!!!

■ Peripheral wiring and internal module circuitry

AI input effective voltage ranges 0V - 10V. The input impedance is 10K. AO output effective voltage ranges 0V - 10V. Currently, AI supports only the voltage inputs.

For the peripheral wiring of the module AX4Y2, connect as follows:

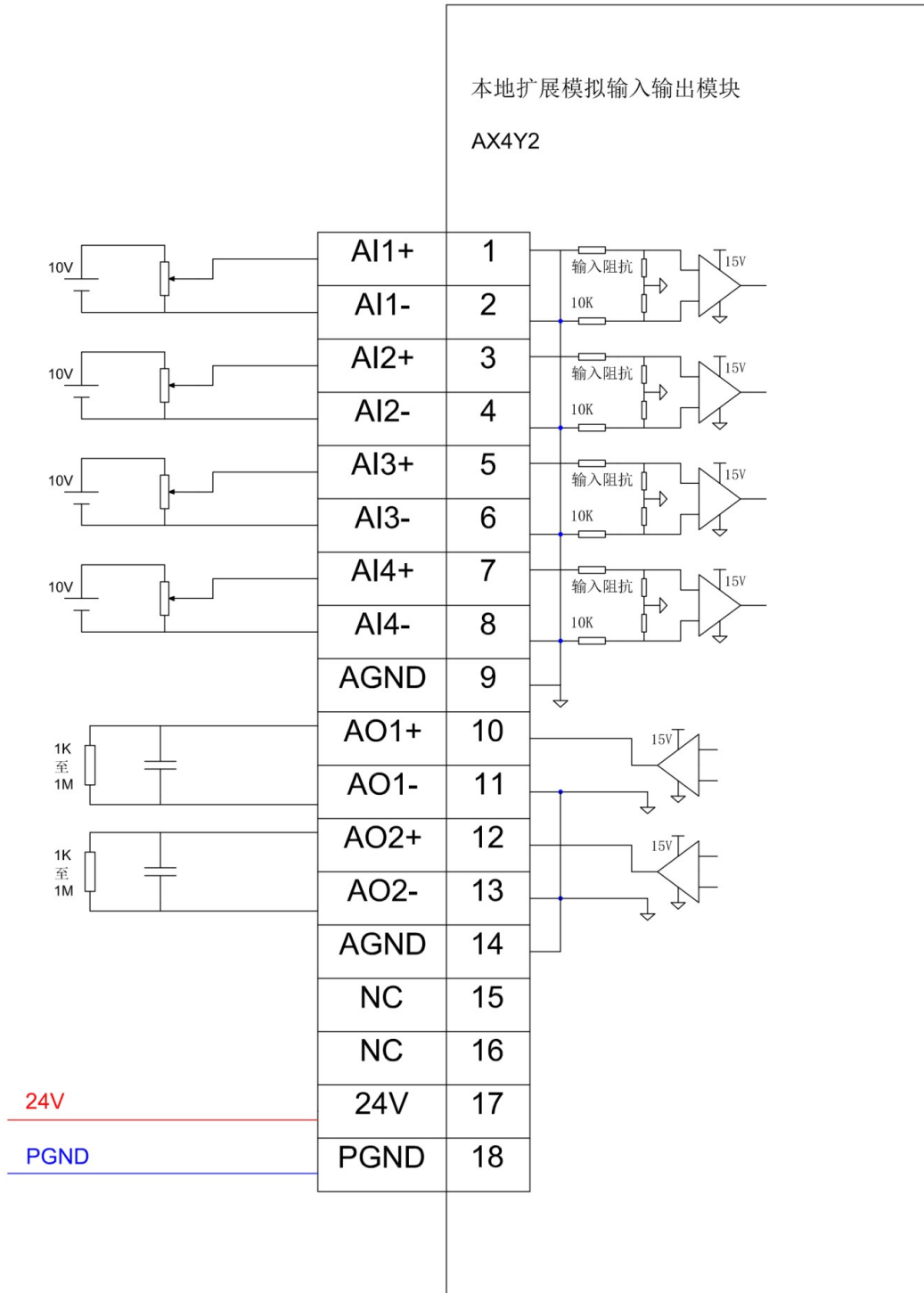

1K 至 1M	1K to 1M
本地扩展模拟输入输出模块	Analog I/O modules for local extension
输入阻抗	Input impedance

## 5.6. Safety precautions

### 5.6.1. Safety precautions

#### ■ Considerations in system design

- Malfunction is sometimes caused by the following reasons in systems using the SC20:  
Deviation in the start and stop times of the SC20's power supply and I/O devices and power equipment.  
Deviation in response time caused by momentary interruption.  
Exceptions to the SC20 main unit, external power supply and other equipment.  
To prevent abnormalities or accidents in the whole system caused by such malfunctions, please take safety measures.

#### ■ Setting of interlock circuits

- When controlling opposite movements of the motor, such as Forward and Reverse, set the interlock circuit outside the SC20.

#### ■ Setting of the E-stop circuit

- Set the circuitry which cuts off the power to the output device in case of emergency to the outside of the SC20.

#### ■ Power sequence

- Start the SC20 after the I/O devices and the power unit have been activated.
- When stopping the SC20, be sure to stop the SC20 before stopping the I/O device or power device if you are not sure how the program relates to the device.
- Since the power down hold circuitry is provided, the system hardware can be guaranteed to be reset by powering up again 30s after a power failure.

#### ■ Grounding

- When installing the SC20 near equipment that generates high voltages due to switching operations of inverters, etc., do not use common grounding but a special ground with a ground resistance of 100Ω or less (Cat D/Cat 3 grounding).

### 5.6.2. Momentary interruption

#### ■ Action in the event of a momentary interruption

- The SC20 will continue to operate if there is a momentary interruption of power for less than 10ms. The operation will change if it exceeds 10ms, depending on the conditions, such as the combination of units and the supply voltage. The same operation as a power reset may be generated.

# **Chapter 6 Confirmation of Wiring**

---

## 6.1. Suggestions for safety circuits

Necessary safety circuits need to be constructed for this equipment

For example:

1. Motor forward and reverse interlock circuit required for drive via servo
2. Overrun switching circuit for motors
3. Power circuit for emergency cut-off of output devices

## 6.2. Confirmations when wiring

- Confirm the connection of each device

Please check that the devices are connected as designed.

- Confirm external safety circuit settings

Make sure that the wiring and installation of the safety circuit overrun switch based on the external circuit is properly installed.

- Confirm the setting of the power-on sequence

Please check that the power-on procedure is set to "Power ON Operation".

- Confirm that the LED display of the SC20 controller is OK

Observe the status of the SC20 controller LED when the power is switched on and consult the LED status display instructions. Determine whether the system is operating properly; if abnormalities occur, refer to the "Troubleshooting" section.

## **6.3. Power ON/OFF operation**

### **6.3.1. Power ON operation**

- Power on the other load devices.
- Power on the SC20 controller.

### **6.3.2. OFF operation**

- Make sure that the load equipment has stopped operating and then power off the SC20 controller.
- Power off the load equipment.

# **Chapter 7 Confirmations Prior to Operation**

---

## 7.1. Confirm that the power ON and network is created

■ **Please power on according to the following procedures.**

- Power on the I/O devices connected to the SC20 controller.
- Power on the servo drive.
- Power on the SC20 controller.
- Make sure that the SC20 controller's action status LED is in the normal run state when the SC20 is powered on.

# **Chapter 8 USB Flash Disk Operation**

---

## 8.1. The way to insert the USB flash disk

1. Snap the side of the battery cover with your hand.

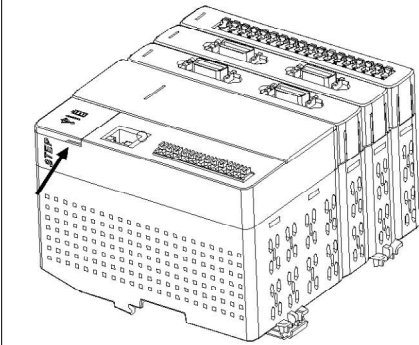

2. Flip the battery cover upwards.

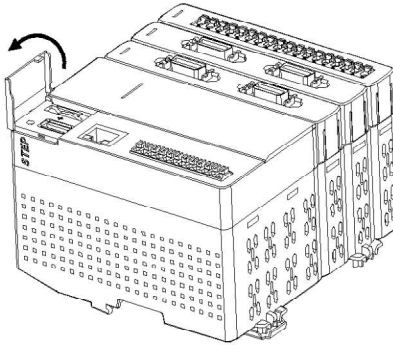

3. Insert the USB flash disk into the appropriate port.

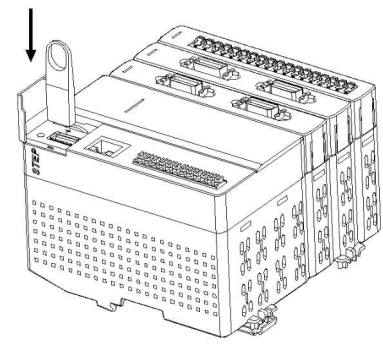

## 8.2. U-copy file operations

Please refer to the Software Manual.

# Chapter 9 System Reset

---

## 9.1. Reset the unit using the RESET button on the SC20 main unit

### ■ Position of the RESET button in SC20

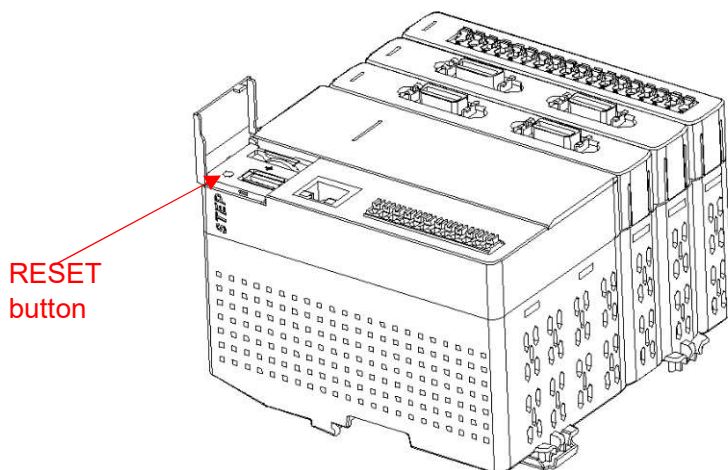

### ■ Key function

Item		Time required to press and hold the RESET button	Outcome
At start-up	Keys operation	Long press for 2s	Not starting the codesys project
	Insert the USB flash disk	USB flash disk stick with firmware to be upgraded	Access the USB flash disk to update the system firmware
Under operation		2s	Stop the current program

# Chapter 10 Troubleshooting

---

## 10.1. System status

LED	Main module status	Handling
Blue LED always ON	Normal	
Red LED always ON	Program exceptions	Please check the System log
Red, blue and green	Not defined	

LED	Slave module	Handling
Blue LED always ON	Work properly	
Red LED always ON	Work improperly	Please check the status of the software
Blue LED flashes	Under communications	

## 10.2. Solutions for exceptions

General solutions:

1. Double click on the problematic node in the left view, and check the status in the online state. Analyze and operation according to the error prompt.
2. Open the System Log to view the error message.
3. Please contact after-sales service for further information.

Fault	Possible solution
Failure to log in to the controller	Confirm that the PC and the controller are on the same network segment and that the IPs are not duplicated; Restart the gateway; Switch off the emulation mode of the controller; If it is an illegal user procedure, switch on and long press the RESET button.
No program running when the main panel displays IDLE	Download the user programs; User illegal program, to be downloaded after modification
Red light of master module LED always ON	Check system logs to analyze the cause
Red light of slave module LED always ON	Please check the software status to analyze the cause
The system is starting up and stops at the startup picture	Firmware upgrade failed, or key files artificially deleted. Please contact the after-sales service.

- Please provide the basic software version number, hardware model number, which can be viewed in the log, when contacting the after-sales service.

# **Chapter 11 Maintenance & Inspection**

---

## 11.1. Inspection

To ensure optimal use, please carry out daily or periodic checks.

### ■ Inspection item

Inspection item	Content	Judgment
Installation status	Mounting on DIN rail, looseness, unit looseness, wobbling	It should be securely installed.
Connection status	Connector is loosened	The connector should be free of looseness.
Surroundings	Ambient temperature and in-cabinet temperature Ambient humidity and in-cabinet humidity	-20°C ~ +55°C 10%RH ~ 90%RH It should be free of dust and corrosive gases.

# **Chapter 12 Specifications and Dimensional Drawings**

---

## 12.1. Specification of the application environment

Item	Specification
Rated voltage	24V DC
Voltage tolerance range	20.4V DC ~ 28.8V DC
Ambient temperature for operation	-20°C ~ +55°C
Ambient temperature for storage	-20°C ~ +80°C
Ambient humidity for operation	10%RH~90%RH, non-condensing
Ambient humidity for storage	10%RH~95%RH, non-condensing
Altitude	0-2km (no limit)
	>2km (ambient temperature decreases by 0.5°C per 100m)
IP grade	IP20
Class of pollution	IE33
Atmospheric pressure	86Kpa ~ 106Kpa
Operating environment	It should be free of corrosive gases; free from heavy dust.
EMC immunity class	According to EN61000-6-X
Weight	< 0.5kg

## 12.2. Performance specification

Item		Specification
Basic frequency of CPU		480MHz
RAM capacity		32M
FLASH capacity		16M
Power-down protection data size		32K
Power-down protection program mode		Flash hold
Power-down hold power-up wait time		35s
Mains input		Max. 1A for DC22V-28V
Instruction cycle		2ns
Module components	Max. number of extension points	512
	Max. number of local bus modules	8
	Max. number of remote EtherCAT nodes supported	16
Motion control	Max. number of axes	16-axis
	Max. number of pulse axes	4 (integrated) + 10 (STEP LBUS extension)
	Number of axes within 1ms	16
	Number of linked interpolation axes	6
	Min. cycle time for EtherCAT axis control	120us
CNC+PLCOpen (electronic cams, groups of axes, etc.)		Support
Supported interfaces		RS232/RS485/CAN
Industrial bus		EtherCAT/Modbus
Edge Computing/IoT		Support
Development software		STEP Automation Studio(codesys)

### ■ List of current consumption

Type of unit		Current consumption	Current increase part
SC20 Controller Standalone	—	0.2A	—
When connecting extension boards	Local extension digital input boards	—	0.1A
	Local extension digital output boards	—	0.1A
	Analog I/O boards for local extension	—	0.1A

## 12.3. Specification of the SC20 Controller body

### 12.3.1. High-speed input specification of the SC20 Controller

Item	Specification	
	Input A, B, Z signals	
	24V DC	5V DC
Insulation mode	Optocoupler isolation	
Rated input voltage	24V DC	5V DC
Operating voltage range	20.4V DC ~ 28.8V DC	3.5V DC ~ 5.5V DC
Input resistance	4.7k $\Omega$	510 $\Omega$
Min. ON voltage / Min. ON current	10V DC / 4mA	3V DC / 4mA
Max. OFF voltage / Max. OFF current	2V DC / 2mA	1V DC / 0.5mA
Common terminal mode	Independent common terminal at each point	
Fastest supported frequency	4Mbps	

### 12.3.2. Specification of the high-speed (pulse) output of the SC20 Controller

Item	Specification
Control loop voltage	5VDC
Rated load current	0.1A/point
Max. voltage drop at ON	0.2V
Leakage current at OFF	Below 0.1mA
Output frequency	4Mbps
Common terminal mode	4 points / 1 common terminal

### 12.3.3. Input specifications of the SC20 Controller

Type	Item	Specification
Digital input	Insulation mode	Optocoupler insulation
	Rated input voltage	24V DC
	Rated input current	Less than 6mA (24DC)
	Input resistance	4.7 k $\Omega$
	OFF voltage /OFF current	2.4V / 1mA
	ON/OFF response time	> 0.01ms (less than 10k)
	I/O refresh mode	Synchronous I/O refresh or free running refresh optional
	Common terminal mode	12 points / 1 common terminal
	I/O connection mode	In-line connectors
Analog input	Input channel	2
	Supply voltage	0–10V
	Voltage input impedance	10k
	Voltage input range	0-10V
	Resolution	12-bit
	Sampling time	1ms
	Accuracy	$\pm 1\%$ full accuracy
	Limit voltage	+15V
	Max. common-mode voltage between channels	15V
	Isolation mode	Between I/O terminals and power supply: capacitive isolation Between channels: Non-isolated (both analog-digital and analog-analog)
	Common terminal mode	2 points / 1 common terminal
I/O connection mode	In-line connectors	

■ Limit on the number of simultaneous ON points for the inputs of the controller body (max. 32 points without 2 analog points)

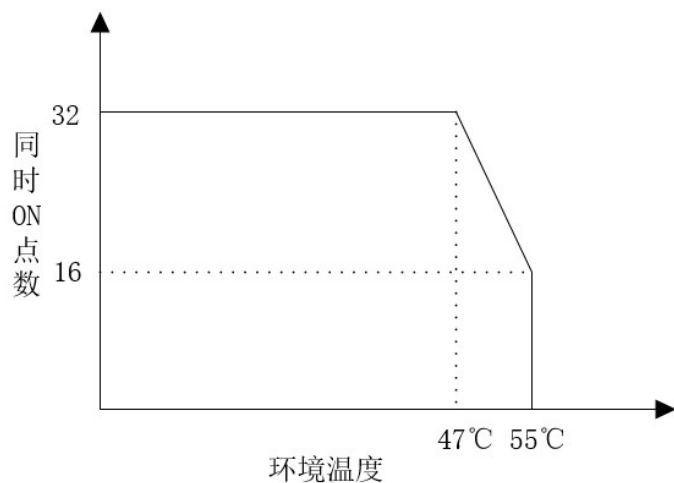

同时 ON 点数	Simultaneous ON points
环境温度	Ambient temperature

### 12.3.4. Output specifications of the SC20 Controller

Item	Specification
Insulation mode	Optocoupler isolation
Output form	NPN output type
Working load voltage range	20.4V DC~28.8V DC
Max. load current	0.5A
Max. surge current	1A
I/O refresh mode	Synchronous I/O refresh or free running refresh optional
Max. voltage drop when ON	Below 1V
ON/OFF response time	>0.01ms (less than 10k)
Circuit protection	Overcurrent, overvoltage, short circuit
Common terminal mode	4 points / 1 common terminal
I/O connection mode	In-line connectors

- Limit on the number of simultaneous ON points for the output of the controller body (max. 12 points)

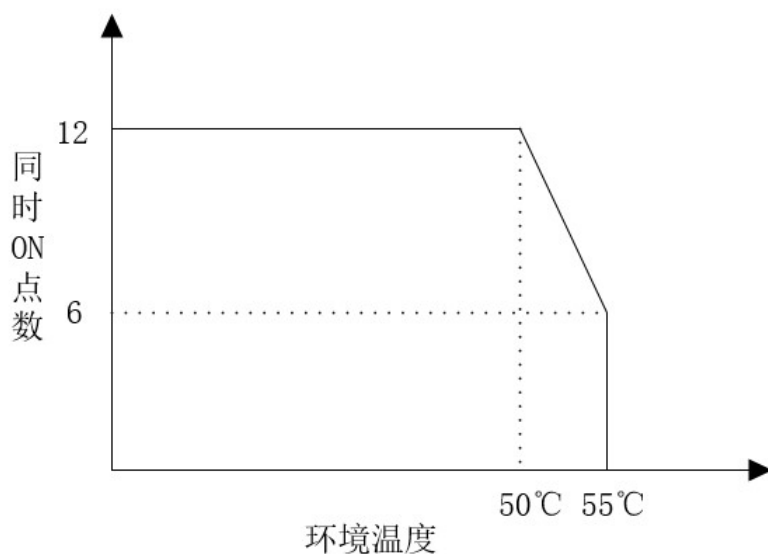

同时 ON 点数	Simultaneous ON points
环境温度	Ambient temperature

## 12.4. Specification of the extension module

### 12.4.1. Specifications for local extension digital input modules

Item	Specification
Insulation mode	Optocoupler insulation
Rated input voltage	24V DC
Rated input current	Less than 6mA (24DC)
Input resistance	4.7k $\Omega$
OFF voltage	2.4V
/OFF current	/1mA
ON/OFF response time	> 0.01ms (less than 10k)
I/O refresh mode	Synchronous I/O refresh or free running refresh optional
Common terminal mode	Common anode connection/Common cathode connection
Power supply mode	Bottom bus
I/O connection mode	In-line connectors

■ Limit on the number of simultaneous ON points for the inputs of the local extension digital input board (max. 16 points)

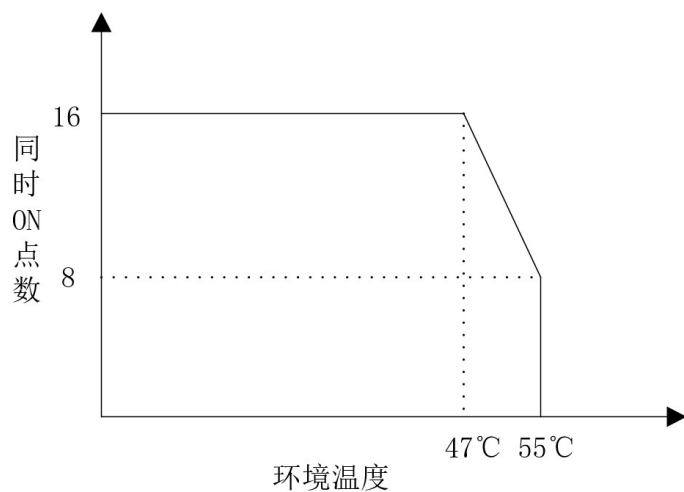

同时 ON 点数	Simultaneous ON points
环境温度	Ambient temperature

### 12.4.2. Specifications for local extension digital output modules

Item	Specification
Insulation mode	Optocoupler isolation
Output form	NPN output type
Working load voltage range	20.4V DC ~ 28.8V DC
Max. load current	0.5A
Max. surge current	1A
I/O refresh mode	Synchronous I/O refresh or free running refresh optional
Max. voltage drop when ON	Below 1V
ON/OFF response time	> 0.01ms (less than 10k)
Circuit protection	Overcurrent, overvoltage, short circuit
Common terminal mode	16 points / 1 common terminal

#### ■ Limit on the number of simultaneous ON points for local extended digital output (max. 16 points)

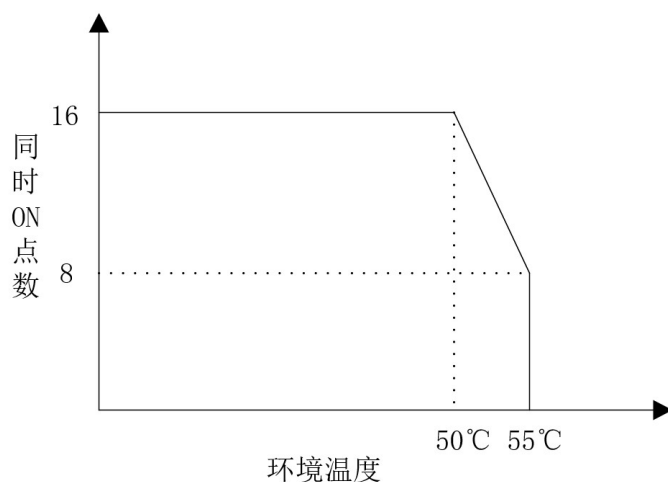

同时 ON 点数	Simultaneous ON points
环境温度	Ambient temperature

### 12.4.3. Specifications of local extension I/O modules

Item	Specification
Insulation mode	Optocoupler insulation
Rated input voltage	24V DC

Rated input current	Less than 6mA (24DC)
Input resistance	4.7k $\Omega$
Output form	NPN output type
Working load voltage range	20.4V DC ~ 28.8V DC
Max. load current	0.5A
Max. surge current	1A
OFF voltage /OFF current	24V /1mA
Max. voltage drop when ON	Below 1V
ON/OFF response time	> 0.01ms (less than 10k)
Circuit protection	Overcurrent, overvoltage, short circuit
I/O refresh mode	Synchronous I/O refresh or free running refresh optional
Common terminal mode	Common anode connection
I/O connection mode	In-line connectors

#### 12.4.4. Specifications of local extension analog modules

Item	Specification	
Input specifications	Input channel	4
	Supply voltage	0—10V
	Internal 5V power consumption	0.1A
	Voltage input impedance	10k
	Voltage input range	0-10V
	Resolution	12-bit
	Sampling time	40us/channel
	Accuracy	0.005V
	Limit voltage	+15V
	Max. common-mode voltage between channels	15V
	Isolation mode	Between I/O terminals and power supply: capacitive isolation Between channels: non-isolated
Output specifications	Output channel	2
	Supply voltage	24V DC (20.4V ~ 28.8V DC)
	Internal 5V power consumption	0.1A
	Voltage output load	1kΩ ~ 1MΩ
	Voltage output range	0-10V
	Accuracy	0.005V
	Resolution	12-bit
	Transition time	40us/channel
	Isolation mode	Between I/O terminals and power supply: capacitive isolation Between channels: non-isolated
Output short-circuit protection	None	
Power supply mode	5V for control of bottom bus, and powered by 24V terminals	
I/O connection mode	In-line connectors	

- Limit on the number of simultaneous ON points for the input of a local extension analog units (max. 4 points)

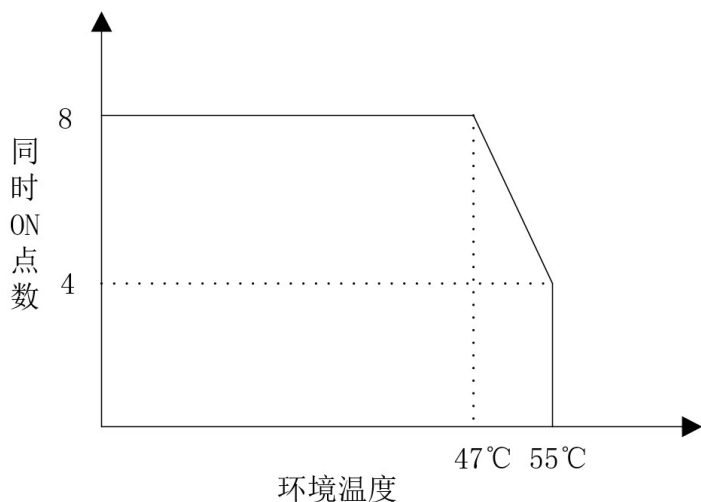

同时 ON 点数	Simultaneous ON points
环境温度	Ambient temperature

■ Limit on the number of simultaneous ON points for the output of local extension analog units (max. 2 points)

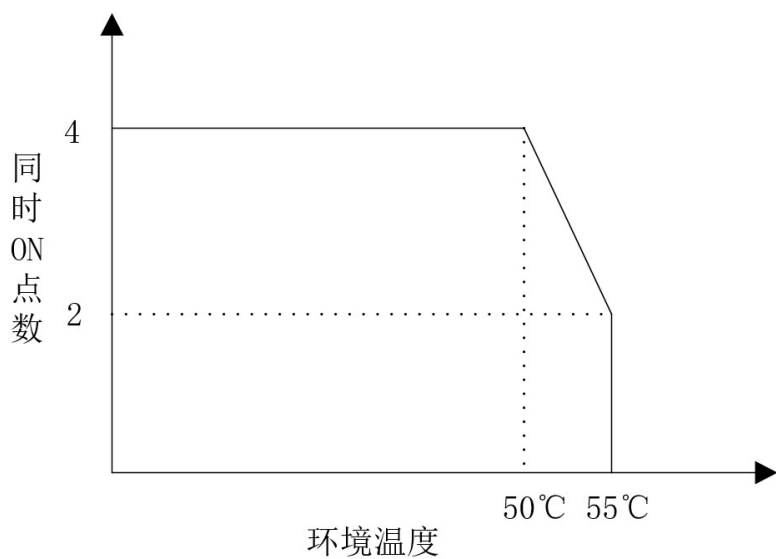

同时 ON 点数	Simultaneous ON points
环境温度	Ambient temperature

## 12.5. Communication specifications

### 12.5.1. USB port specifications

Item	Specification
Standard	USB2.0 Fullspeed
Connector shapes	Type A USB

### 12.5.2. Specifications of COM ports

#### ■ Specifications of RS-232 ports

Item	Specification
Number of CHs	1
Physical layer	RS-232
Transmission distance	Max. 15m
Type of communication	1:1 communication
Mode of communication	Half-duplex
Transmission link	Multi-core shielded cable
Transmission rate	9600/19200/38400/57600/115200bps
Connector mode	In-line connectors

#### ■ Specifications of RS485 ports

Item	Specification
Number of CHs	1
Physical layer	RS-485
Transmission distance	1,000m (19.2 kbps)/100m (115.2 kbps)
Type of communication	1:1 communication
Mode of communication	Half-duplex
Transmission link	Multi-core shielded cable
Transmission rate	Max. transmission rate of 115.2 kbps
Connection mode	In-line connectors

### ■ Basic CAN port specifications

Item	Specification
Number of CHs	1
Physical layer	CAN
Transmission distance	Max. 15m
Type of communication	1: n communication
Mode of communication	Half-duplex
Transmission link	Multi-core shielded twisted pair
Transmission rate	10K/20K/50K/125K/250K/500K/800K/1Mbps
Connection mode	In-line connectors

### 12.5.3. LAN port specifications

Item	Specification	
Port definitions	1-channel Ethernet (available for EtherCat)	
Default address	Default address of STEP.Eth1.IP is 192.168.0.11	
Communication interface	Ethernet	
Communication speed	100 Mbps/10 Mbps Auto-negotiation	
Physical layer	100BASE-TX	
Transmission distance	100m (max. 100m, anti-interference measures such as the installation of ferrite cores are required for some applications) It is also recommended to locate the hub near the control panel and to use it within 10m)	
Communication cable	Twisted-pair cable (with shield: STP): Cat 5e or higher	
Communication protocol	TCP/IP	
Number of slave connections	———— (maximum number of EtherCat slaves is 16)	
Topology structure	Linear topology	
Mode of communication	Full/half-duplex mode	
TCP/IP protocol	TCP/IP (IPV4) compliant	
Function	Change and maintain network settings (IP, Subnet, Gateway) Same/different network settings can be set between Ethernet ports No routing between Ethernet ports	
LED display	LINK	Lights up when a connection is established between devices on the Ethernet
	ACT	Flashes when communicating with the connected device in various ways, such as sending and receiving commands and responses

## 12.6. Other specifications

### 12.6.1. USB flash disk specifications

Item		Specification
USB flash disk	Max. capacity supported	Unlimited
	Standards supported	USB2.0
	Action detection	None

## 12.7. Dimensional drawing

### 12.7.1. Dimensional drawing of the SC20 Controller

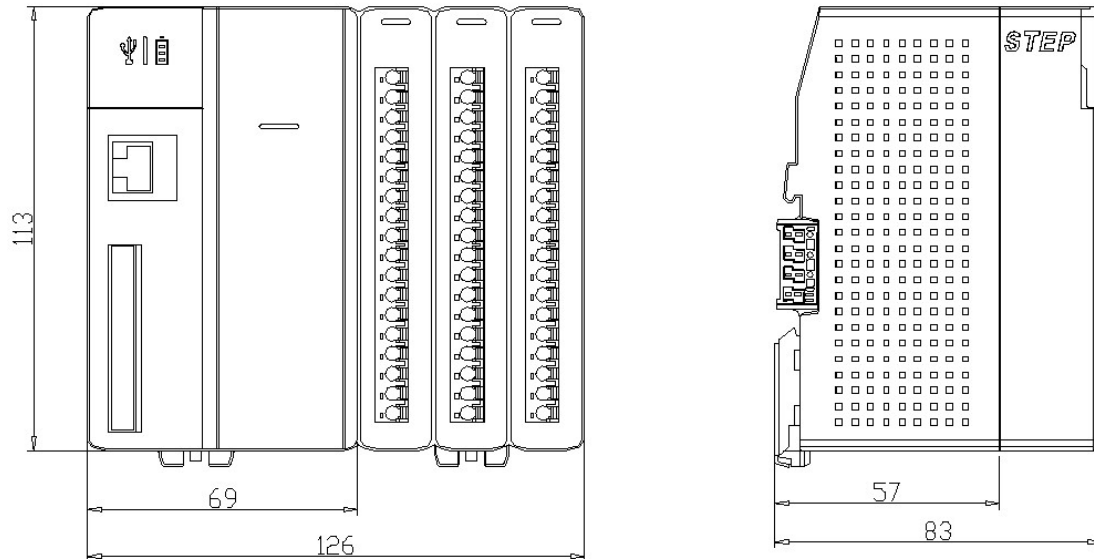

### 12.7.2. Dimensional drawing of the SC20 local extension module

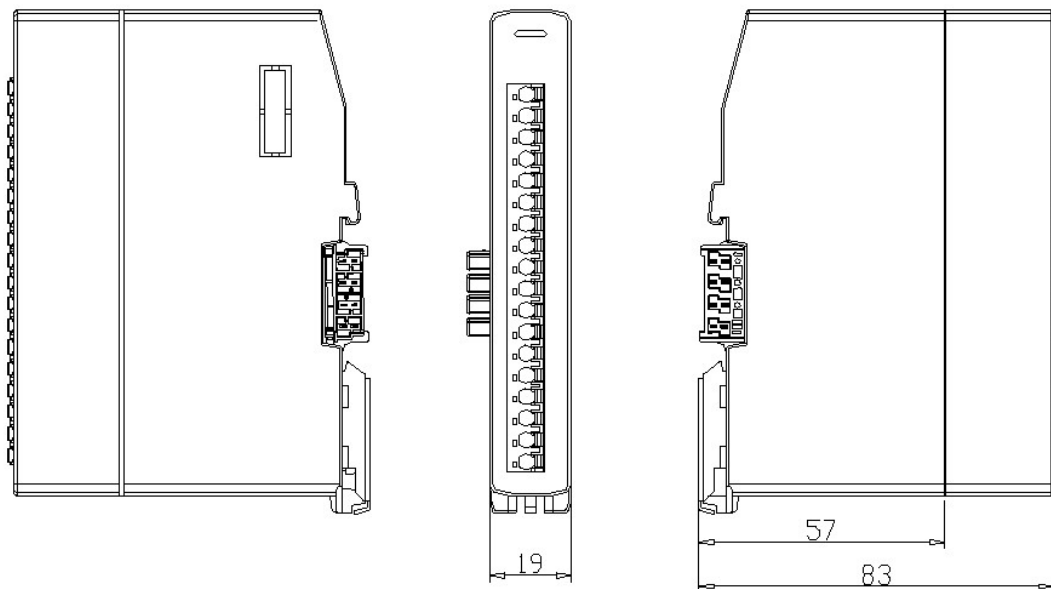

## **Chapter 13 Appendix 1 Notes on Upgrade/Warranty**

---

## 13.1. Warranty

### ■ Warranty period

The warranty period is 1 year from the date of purchase or 1 year and 6 months from the month of manufacture.

### ■ Warranty coverage

In the event of a breakdown caused by our company during the warranty period, we will replace or repair the defective part of the purchased machine unit. Moreover, the liability of our company is limited to the replacement and repair of the purchased machine, and we are not liable for any damage caused to you or third parties as a result of the breakdown of the purchased machine.

We shall not be liable for any damage to you or to third parties due to the machine being in poor condition under any of the following circumstances, other than those stated in the "Warranty period".

1. If the machine is not assembled or used in accordance with the instructions or precautions described herein;
2. When the machine is not matched to the product assembled in the machine;
3. If the matters described herein that rely on you cannot be matched;
4. In the event that the machine is in poor condition for reasons other than us.

### ■ Precautions for use

- Precautions for the export of the product and machines fitted with the product
- If the end-user or end-use of the product is associated with military or weapons, the product is subject to export control under the *Foreign Exchange and Foreign Trade Control Act of Japan*. Therefore, adequate checks and necessary export procedures are required when exporting such products.
- The product is designed and manufactured for general industrial products, and is not intended for use in machinery or systems related to human life.
- Set-up, wiring, operation, maintenance and spot checks must be carried out by experts with knowledge of product use.
- Please install a safety device if a major accident or damage to the equipment is predicted due to the failure of the product.
- The product is designed for general industrial products. DO NOT use the product in atomic energy control, aerospace equipment, transportation agencies, medical equipment, safety equipment, etc., where the safety of people is at stake, or in special environments.

- Please also check the noise immunity of the machine yourself as the wiring conditions (grounding method, cable length, shielding of the signal cable) may affect the noise immunity.
- Smoke may be visible to the extent of a cigarette, depending on the fault content of the product. Please take this into account when using in clean rooms.
- Falling goods may be caused if the product is overloaded, so please handle according to the label.
- DO NOT use the volatile oils, thinners, alcohols, acidic and alkaline detergents, as they may cause discoloration or damage to the outer box.
- Please dispose of the product as industrial waste when it is discarded.
- You are advised to check the appropriateness of the finished product in terms of laws and regulations, as well as the construction, dimensions, life span and characteristics of the installed equipment and components.
- Please note that the product cannot be guaranteed to function properly if used in excess of the specifications of the product.
- The contents of this manual (style, software version, etc.) are subject to change without prior notice due to improvements in product performance.

## **13.2. Repair and maintenance**

- Please contact the product agent as a priority for return maintenance;
- If the product has already been loaded into the equipment, please contact the equipment manufacturer first.

## 13.3. Technical Services

- Customer Technical Consultation

Tel: (86) 13917890469 (Engineer Zhong)

Consultation time: Monday - Sunday 9:00-17:30 (except specific holidays)

- After-sales technology and maintenance consultation (repair of faulty parts, purchase of maintenance parts and optional accessories)

After sales support: 400-168-2718

Purchase Enquiry: 13925286547 (Manager Zhou)

Consultation time: Monday - Sunday 9:00-17:30 (except specific holidays)

- Internet technical information

