

Intelligent drive Control your heart

# Ω6 series AC servo system

Selection Manual



Motion Control | Business Hotline

400-821-0325

VER2.0



WECHAT ACCOUNT (MOTION CONTROL)

The product information stated in the sample is subject to the actual product and is subject to change without prior notice. Please confirm with the sales staff before placing an order.

## About Sigriner

### 1982 .....

In 1982, Anton, a technical engineer from Bavaria, Germany When he founded the company in his garage, he decided to name it after himself. The honor of the family endorses the product quality. SGRINER was the first company to use microprocessors for elevator control. One of the companies in the elevator industry. Sigriner at his home



### 1999 .....

In August 1999, S IGRINER moved to the Hirschwinkel Industrial Park, the company's research and development and manufacturing reached a new level.

### 2003 .....

In 2003, SGRINER formed an alliance with Shanghai STEP to form STEP SGRINER The new company will have complementary advantages between the Chinese and German R&D teams and jointly develop drive and control products. Taste. In 2003, STEP SGRINER increased its investment in drive technology and joined forces with the Chinese team Develop a new generation of energy-efficient and efficient variable frequency drives.

### 2013 .....

In 2013, SGRINER passed the ISO9001 and ISO14001 certifications of TUV. The industry management level is recognized. SGRINER uses some key technologies of variable frequency drive in the development of servo products. Started R&D, production and sales of servo EM series products.

### 2019 .....

On November 2, 2019, SGRINER officially moved to the Mühldorf Industrial The park is ready for the development of new products for general frequency conversion and motion control.



### 2020 .....

In March 2020, SGRINER registered a universal variable Special trademark for high-end products of frequency and motion control, started Entering the field of high-end intelligent manufacturing. In the same year, SGRINER servo drive Ω6 series high-end New products are launched.

## Table of contents

### Ω6 Series AC Servo System Selection Manual

<b>Ω6 Driver</b>	<b>02</b>
Product Features   Naming Rules	
<b>Ω6-A Series Servo Driver</b>	<b>04</b>
Functional configuration   ODSAP6   ODSAN6   Electrical specifications and model list   Driver side accessories	
<b>Ω6-C Series Servo Driver</b>	<b>16</b>
Functional configuration   ODSCP6   ODSCN6   Electrical specifications and model table   Driver side accessories	
<b>Ω6-W Series Dual-Axis Servo Driver</b>	<b>23</b>
Functional configuration   ODMWP6   ODMWN6   Electrical specifications and model table   Driver side accessories	
<b>Ω6 motor</b>	<b>28</b>
Naming rules   Motor performance parameters   Motor size parameters   Motor matching cable naming rules   Cable accessories	

# Ω6 Driver

## Features

### Servo Drives

1. Self-tuning, no debugging required, saving 90% of equipment debugging time
2. New gantry synchronization algorithm + internal dedicated interface, plug and play
3. Full-band vibration sweeps away all the light, curing the robot's Parkinson's disease  
V-type suppression control + terminal vibration control + adaptive notch filter

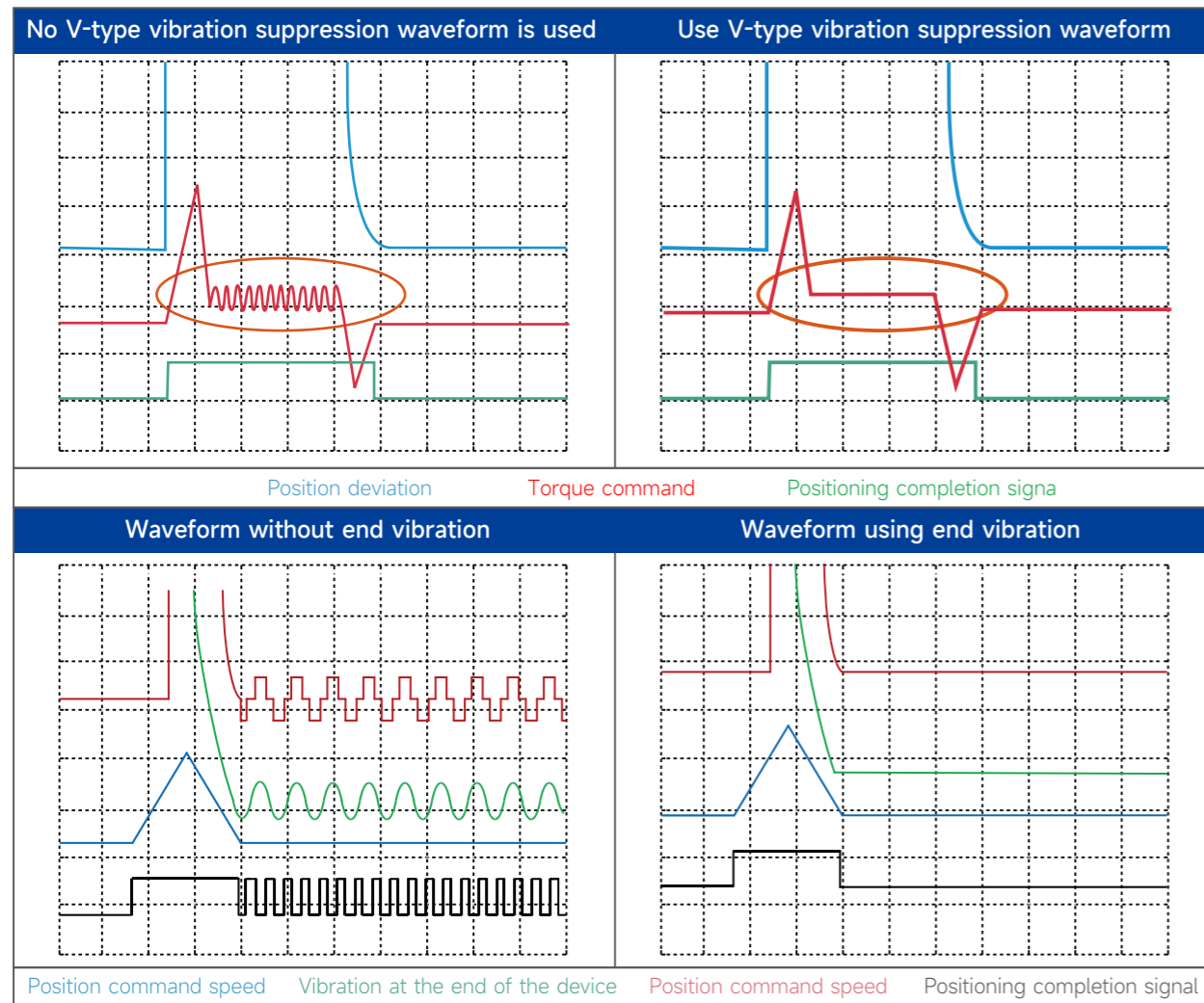

4. Independent heat dissipation duct + temperature monitoring system + thickened UV coating to resist harsh environments such as high humidity, high temperature, dust, etc.
5. Linear drive  
Position comparison output: Perfect match with the system, using flying camera, adaptive running speed  
Hall commutation self-learning: For linear motors with Hall type, complete Hall sequence learning with one click  
Equipped with a new HD linear algorithm: Equipped with self-tuning function to maximize the output capacity of the linear motor, perfect following error compensation: directly import the data table of the laser interferometer test, and automatically generate the compensation table.

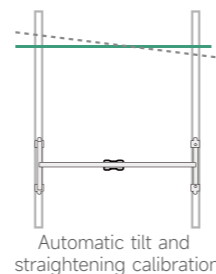

## Naming convention

ODS	AP6	A	401	G	B	**
1-3	4-6	7	8-10	11	12	13-14

1-3 Product Categories	ODS: Single-axis servo drive	
	ODM: Dual-axis servo drive	
4-6 Product range	AP6: Ω6-A single axis series pulse type	
	AN6: Ω6-A single-axis series bus type	
	CP6: Ω6-C single axis series pulse type	
	CN6: Ω6-C single-axis series bus type	
	WP6: Ω6-W dual-axis series pulse type	
	WN6: Ω6-W dual-axis series bus type	
7 Voltage level	A: AC220V	
	B: AC380V	

8-10 Power specifications (rotary type)  Continuous operating current (linear)	Rotary Type	Straight
	201: 200W	3D2: 3.2A
	401: 400W	5D6: 5.6A
	751: 750W	007: 7.0A
	102: 1kW	9D7: 9.7A
	.....	.....
	44: 400W*dual axis	44: 3.2A*dual axis
77: 750W*dual axis	77: 5.8A*dual axis	
11 Specifications	B: Basic	G: General purpose
	G: General purpose	
	F: Full-function type (only available in Ω6-A)	
12 Encoder interface type	B: Serial communication	B: ABZ incremental/BISS C
13-14 Drive Type	Space: Rotary drive	L: Linear drive

# Ω6-A Series Servo Driver

Excellent performance, rich functions, power coverage 100W~7.5kW



## Function Configuration

Function	ODSAP6 Specifications			ODSAN6 Specifications		
	General Type (G)	Full-featured type (F)	Straight line (GBL)	General Type (G)	Full-featured type (F)	Straight line (GBL)
USB Communication	✓	✓	✓	✓	✓	✓
Modbus	✓	✓	✓			
EtherCAT				✓	✓	✓
STO safety function		✓	✓		✓	✓
Command pulse input	✓	✓	✓			
Encoder frequency division output (ABZ)	✓	✓	✓	✓	✓	✓
Analog voltage input	✓	✓	✓	✓	✓	✓
Second encoder		✓	✓		✓	✓
High-speed DI	✓	✓	✓	✓	✓	✓
High-speed DO	✓	✓	✓	✓	✓	✓
Probe	✓	✓	✓	✓	✓	✓
Flying Shoot	✓	✓	✓	✓	✓	✓
Gantry function		✓	✓		✓	✓
Brake module	✓	✓		✓	✓	
Positioning compensation	✓	✓	✓	✓	✓	✓
Hall commutation self-learning			✓			✓
Black Box	✓	✓	✓	✓	✓	✓

## ODSAP6 Technical Specifications

Technical specifications		Describe		
Conditions of Use	Operating temperature	- 5°C ~ 55°C (no freezing; if a battery box is installed or braking is used, the rating will be reduced by 10°C. That is 45°C; when the temperature exceeds 45°C, the power will be derated by 10% for every 5°C increase)		
	Storage temperature	-20°C ~ 70°C		
	Operating/Storage Humidity	Below 95%RH (no freezing or condensation)		
	Vibration resistance	5.88m/s <sup>2</sup> or less, 10Hz (cannot be used continuously at resonant frequency)		
	Impact strength	19.6		
	Altitude	Normal use below 1000m, please derate for 1000m ~ 2000m		
Encoder feedback	First encoder	Serial communication/single-ended Hall signal		
	Second encoder	ABZ/BISS-C		
IO interface connector	Digital Signal	Enter	10 general inputs, 3 of which are high-speed DIs. Select the function of the general input according to the parameters	
		Output	6 general outputs, 2 of which are high-speed DOs. The function of the general output is selected according to the parameters	
	Analog signal	Enter	3-channel 16-bit A/D, ±10V	
		Output	2-channel 12-bit D/A, ±10V	
	Pulse signal	Enter	2 inputs; differential input maximum 16Mpps, pulse width cannot be less than 62.5ns The maximum input of the optocoupler is 1Mpps, and the pulse width cannot be less than 2us (it can support 5V, 12V and 24V input)	
		Output	4 outputs; A, B, Z phase differential output, Z phase open collector output	
Position control mode	Vibration contro	Up to 3 can be used at the same time		
	V-type vibration damping filter	A maximum of 1 can be used at a time		
	2 Degrees of Freedom	Available		
	Load variation suppression control	Available		
	Flying shooting function	Available		
	Torque command input	Torque command can be input according to analog voltage		
	Speed limit function	Speed limit value can be set according to parameters		
Speed control	Zero speed clamp	According to the zero speed clamp input, the internal speed command can be fixed to 0		
	2 Degrees of Freedom	Available		
	Load variation suppression control	Available		
Genera	Automatic Adjustment	The action instructions from the upper level and the action instructions issued by the installation and debugging software Ω Master are driven by the motor. In this state, the load inertia is estimated and determined in real time, and the gain corresponding to the rigidity setting is automatically set.		
	Frequency division function of feedback pulse	The number of pulses can be set arbitrarily (but cannot exceed the number of encoder feedback pulses)		
	Protection function	Hardware Error	Overvoltage, undervoltage, overtemperature, overload, overcurrent, encoder abnormality, etc	
		Software Errors	Position deviation is too large, command pulse frequency division, EEPROM parameter abnormality, etc	
Alarm data tracking function	The alarm data history can be referenced			

# ODSAP6 specification wiring diagram

## A type driver wiring diagram

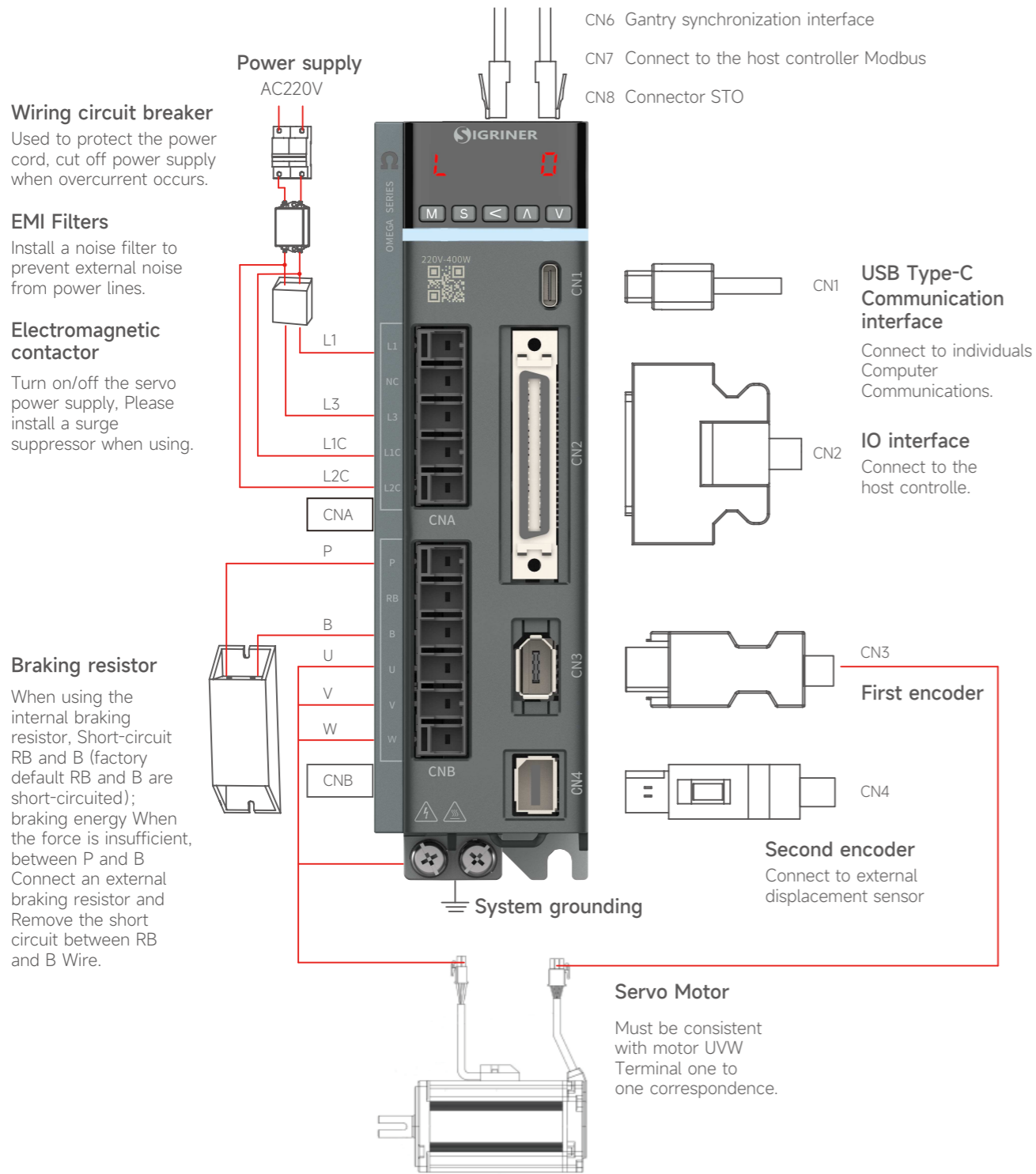

## B-C type driver wiring diagram

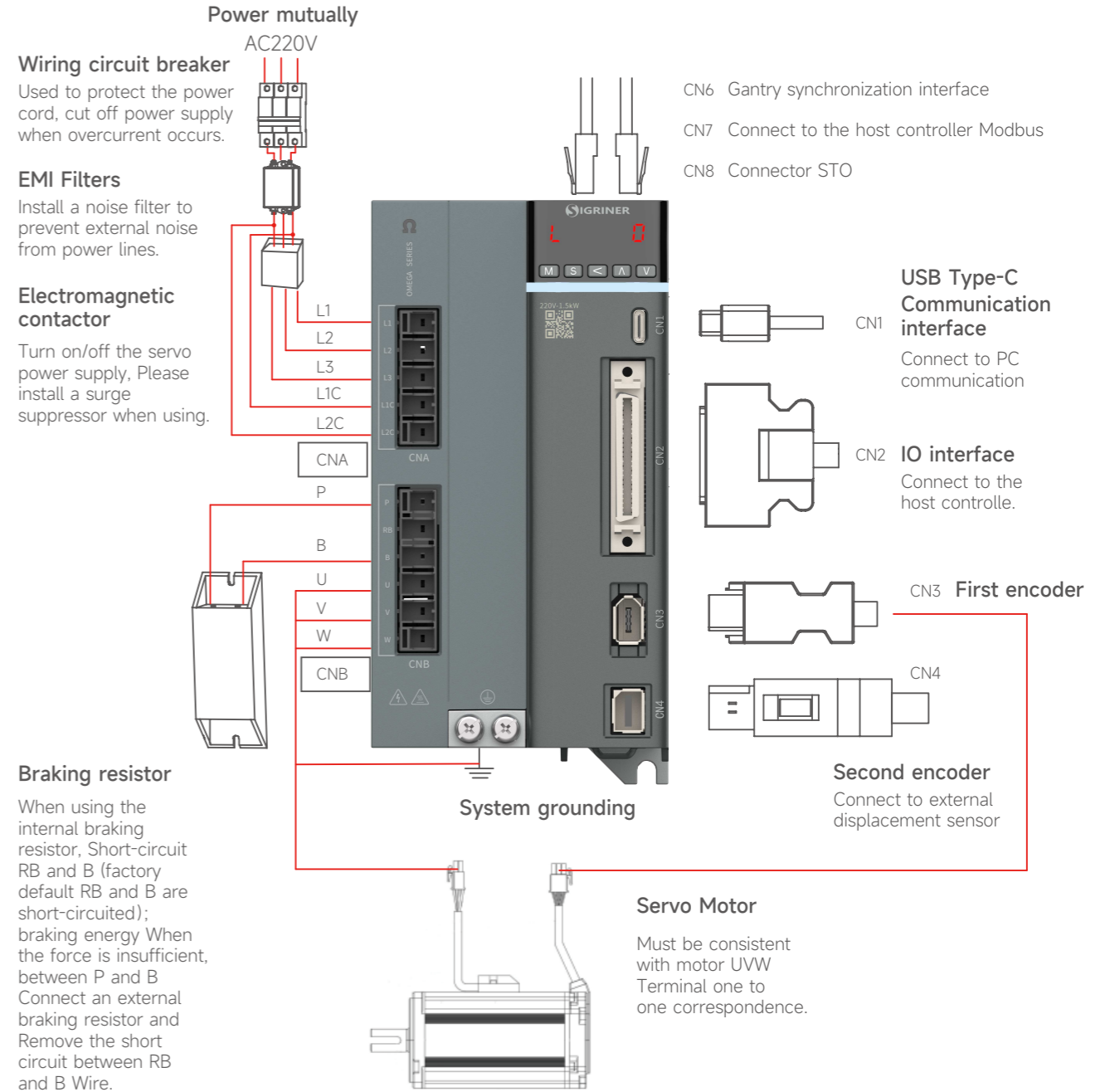

### D~E type driver wiring diagram

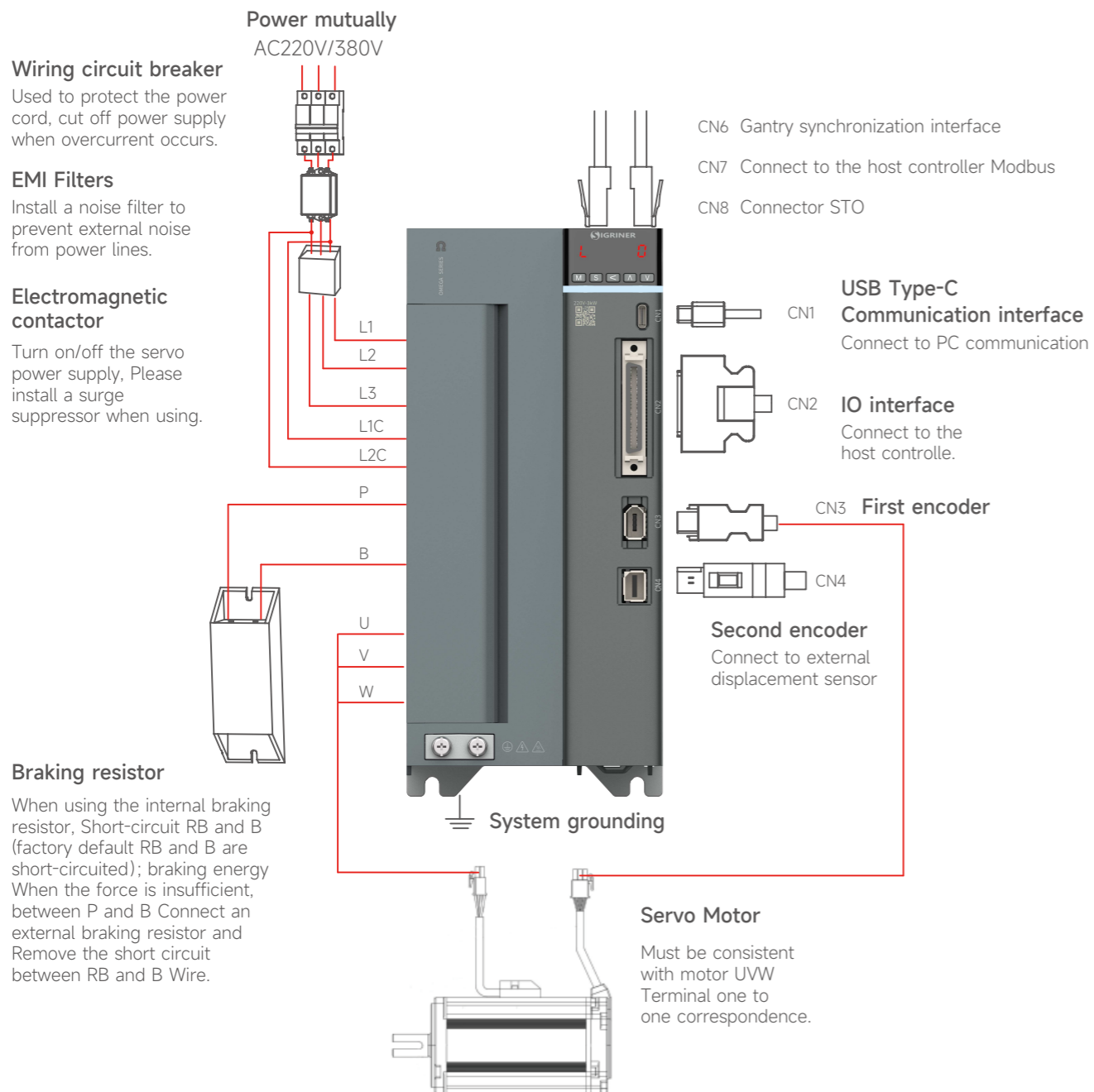

## ODSAN6 Technical Specifications

Technical specifications		Describe	
Conditions of Use	Operating temperature	- 5°C ~ 55°C (no freezing) Note: If using 16K switching frequency, braking resistor and When using ODSAN6A192GB servo, the maximum operating temperature is reduced to 45°C	
	Storage temperature	-20°C ~ 70°C	
	Operating/Storage Humidity	Below 95%RH (no freezing or condensation)	
	Vibration resistance	5.88m/s <sup>2</sup> or less, 10Hz (cannot be used continuously at resonant frequency)	
	Impact strength	19.6m/s <sup>2</sup>	
	Altitude	Normal use below 1000m, please derate for 1000m ~ 2000m	
Encoder feedback	First encoder	Serial communication/single-ended Hall signal	
	Second encoder	ABZ/BISS-C	
IO interface connector	Digital Signal	Enter	8 general inputs, 2 of which are high-speed DIs. Select the function of the general input according to the parameters.
		Output	3 general outputs, 1 of which is high-speed DO. The function of the general output is selected according to the parameters.
	Analog	Enter	1 channel 16bit A/D, ±10V
Pulse signal	Output	3-way, differential output of encoder signal or external displacement sensor signal after frequency division processing (A·B phase). The frequency division ratio can be set by parameters and can be used as the position Use for output.	
Position Control	Vibration contro	Up to 3 can be used at the same time	
	V-type vibration damping filter	A maximum of 1 can be used at a time	
	2 Degrees of Freedom	Available	
	Load variation suppression control	Available	
	Feedforward function	Available (speed/torque)	
	3rd gain switching function	Available	
	Friction torque compensation	Available	
	Hybrid vibration suppression function	Available (only full-featured models available)	
	Quadrant protrusion suppression function	Available	
	Torque limit switching function	Available	
	Motor movable range setting	Available	
	Torque saturation protection function	Available	
	Single-turn absolute function	Available (when connected to an absolute encoder)	
	External displacement sensor position information monitor	Available (only full-featured models available)	

Torque contro	Vibration control	Unavailable	
	Model damping filter	Unavailable	
	3rd gain switching function	Unavailable	
	Quadrant protrusion suppression function	Unavailable	
	Motor movable range setting	Unavailable	
	External displacement sensor position information monitor	Not available (only full functionality available)	
	Lock mode with stop function	Unavailable	
Fully closed loop control (Rotary type)	The second encoder frequency division and multiplication setting range	1/40 ~ 1280 times the ratio of the encoder feedback pulse (numerator) and the external displacement sensor pulse (denominator) can be Numerator = $1 \sim 2^{25}$ , Denominator = $1 \sim 2^{25}$ You can set it arbitrarily within the range, but please use it within the above range	
	Vibration contro	Up to 3 can be used at the same time	
	Load variation suppression contro	Available	
	Flying shooting function	Available	
Speed control	2 Degrees of Freedom	Available	
	Load variation suppression control	Available	
	Feedforward function	Available (torque)	
	Friction torque compensation	Available	
	Torque limit switching function	Available	
	Torque saturation protection function	Available	
General	Single-turn absolute function	Available (when connected to an absolute encoder)	
	Automatic Adjustment	The motor is driven by the action command issued by the upper level and the installation and debugging software Ω Master. In this state, the load inertia is estimated and determined in real time, and the gain corresponding to the rigidity setting is automatically set.	
	Electronic gear ratio setting	1/1000 ~ 1000 times Numerator = $1 \sim 2^{30}$ , Denominator = $1 \sim 2^{30}$ can be set arbitrarily Use within the scope.	
	Notch filter	5 (2 automatic)	
	Gain switching function	Available	
	2-stage torque filter	Available	
	Flying shooting function	Available	
	Protect Function	Hardware Error	Overtoltage, undervoltage, overload, overheating, overcurrent, encoder abnormality, etc.
		Software Errors	Position deviation is too large, EEPROM is abnormal, etc.
		Embedded black box	Monitor operating status in real time, diagnose potential risks, and perform timely maintenance.
Alarm data tracking function	You can refer to the history of alarm data		

## ODSAN6 Technical Specifications

### A type driver wiring diagram

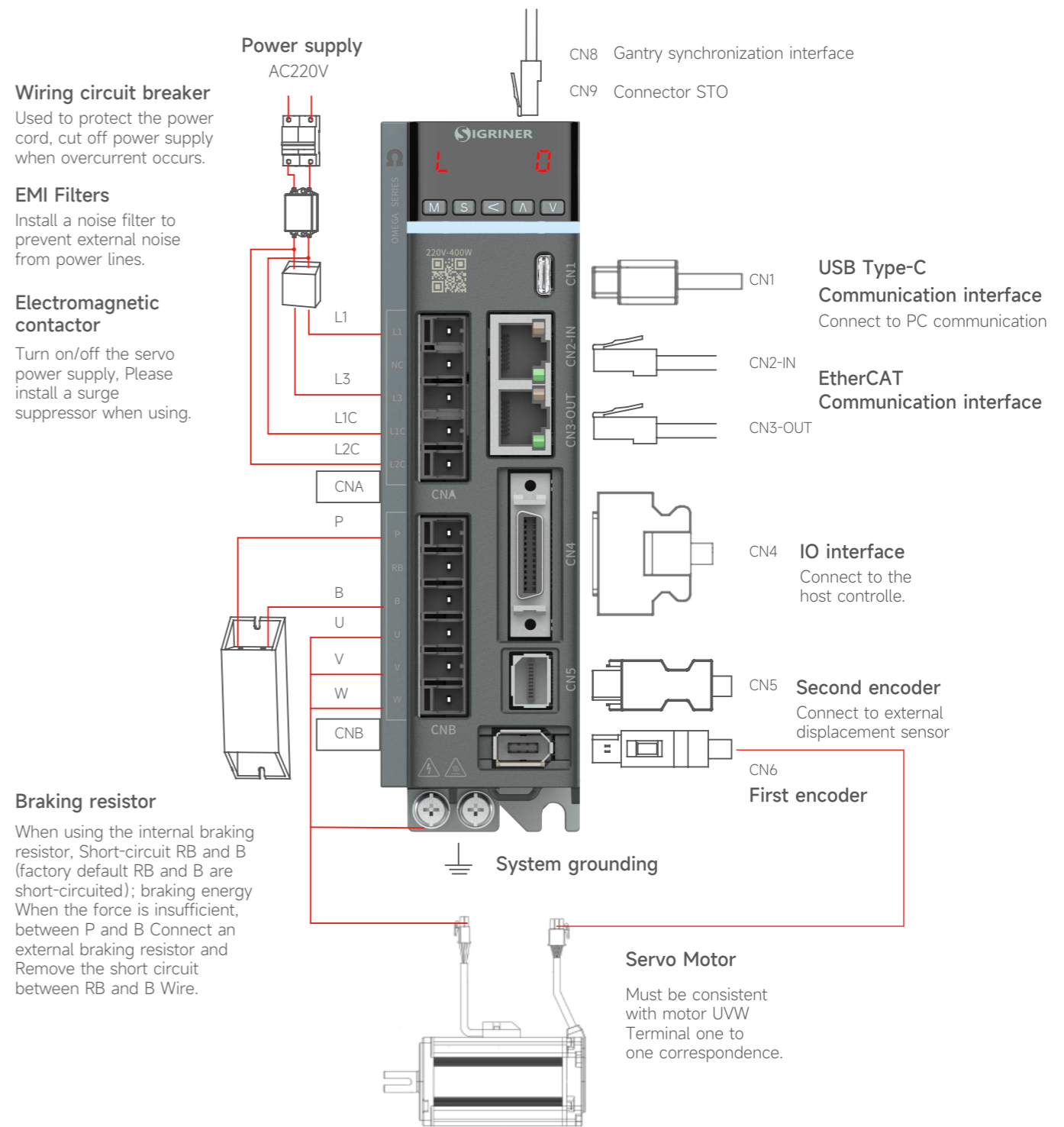

## B~C type driver wiring diagram

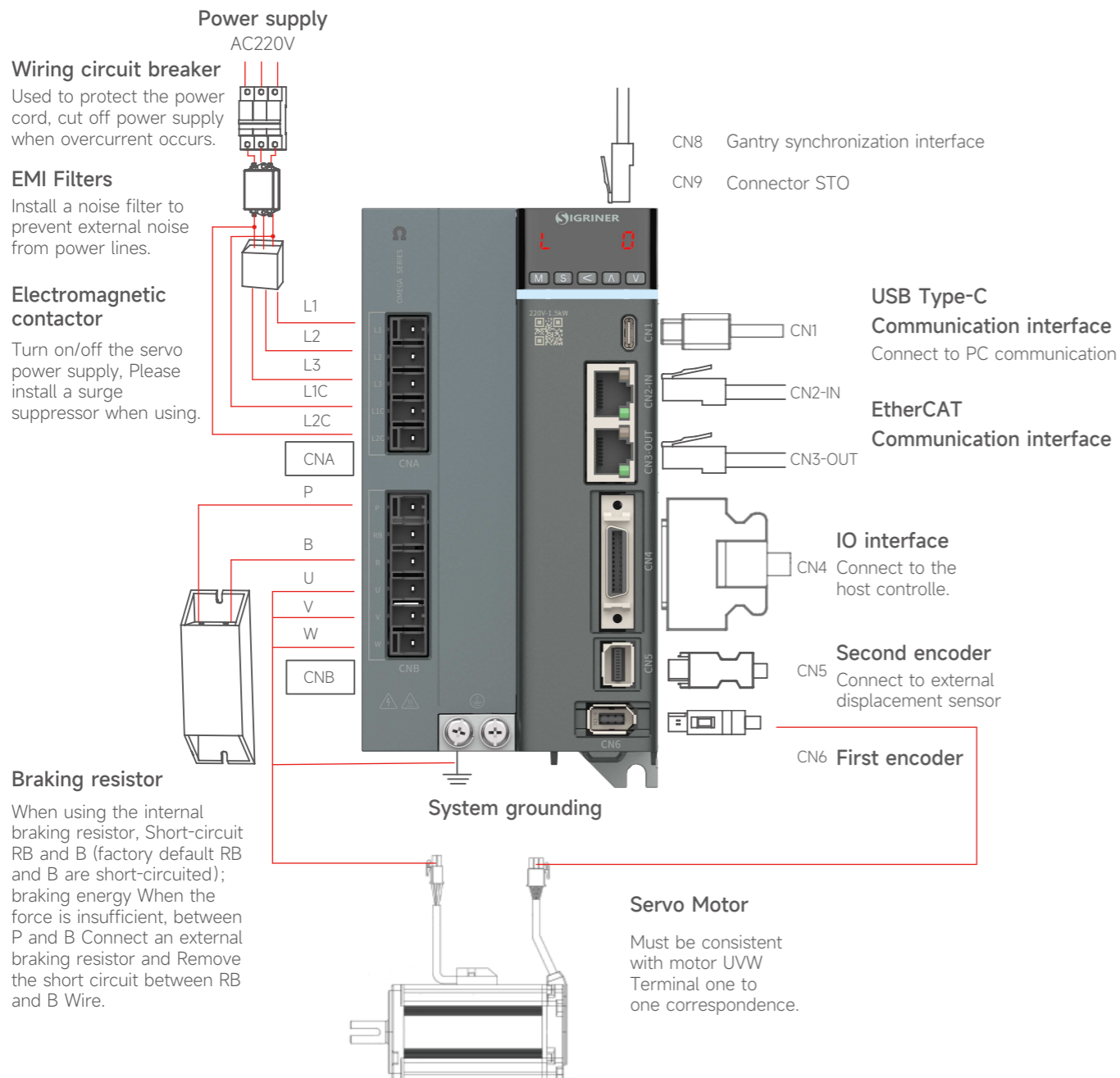

## D~E type driver wiring diagram

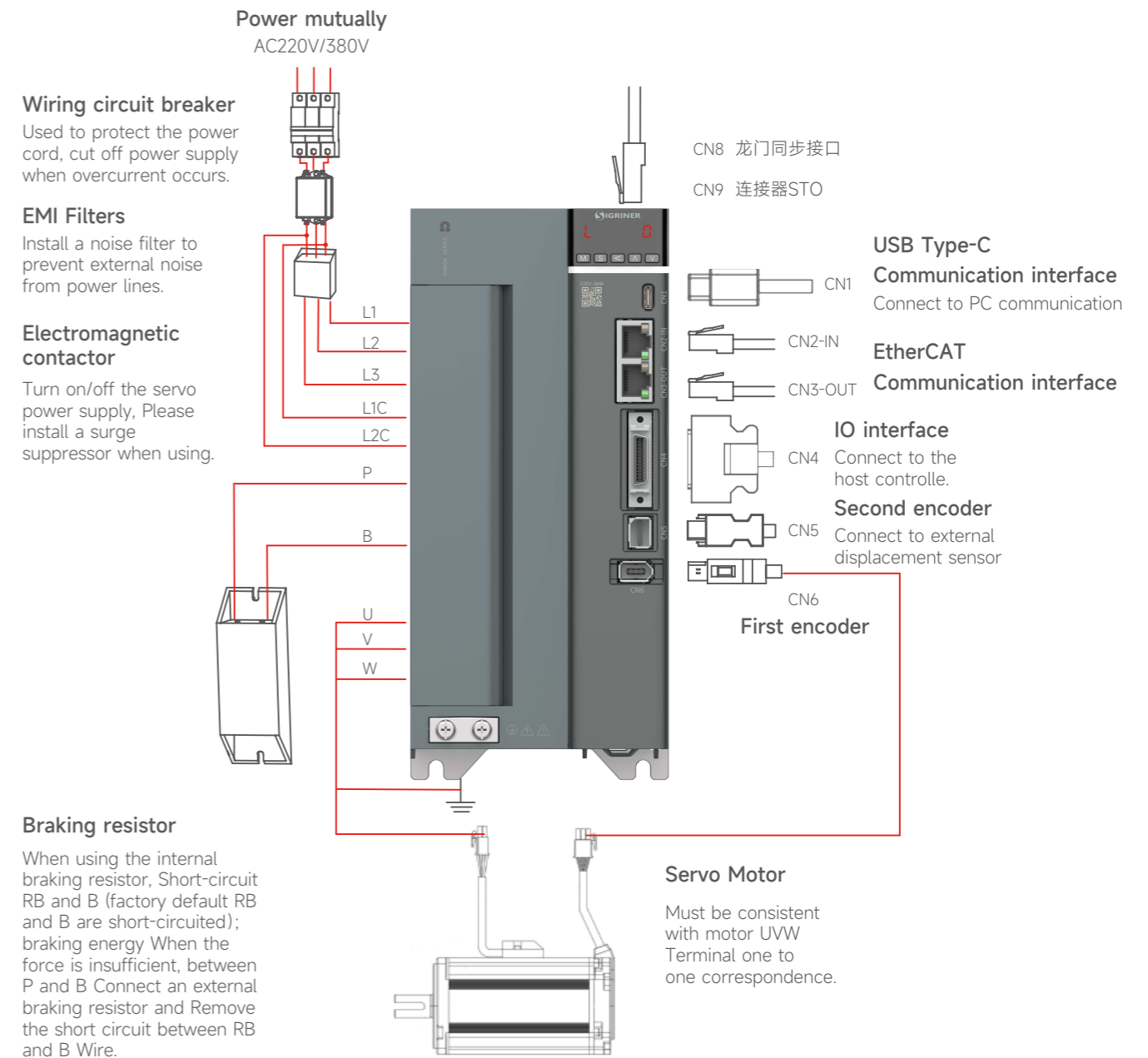





## Electrical specifications and model table

### Electrical specifications

Rotary drive											
Voltage level	220V										380V
Power (kW)	0.2	0.4	0.75	1.0	1.5	2.0	2.0	3.0	4.0	4.5	7.5
Rated current (Arms)	2.1	2.8	5.0	6.0	8.4	11.5	12.5	18.1	24	17	27
Maximum output current (Arms)	6.3	9.8	15	18	30	33	37.5	54.3	56	51	70
Dimensions	Type A		Type B		Type C		Type D			Type E	
Main circuit power supply	Single phase AC200~240V -15%~10%		Single/three-phase AC200~240V -15%~10%			Three-phase AC200~240V -15%~10%			Three-phase AC380~440V -10%~10%		
Control circuit power supply	Single Phase AC200~240V, -15%~10%									Three-phase AC380~440V -10%~10%	

Linear drives										
Voltage level	220V								380V	
Model code	3D2	5D6	007	9D7	014	021	021	040		
Continuous operating current (Arms)	3.2	5.6	7.0	9.7A	14.4	20.8	21	40		
Maximum output current (Arms)	9.8	15	18	30	37.5	54.3	51	92		
Dimensions	Type A		Type B		Type C		Type D		Type E	
Main circuit power supply	Single phase AC200~240V -15%~10%		Single/three-phase AC200~240V -15%~10%			Three-phase AC200~240V -15%~10%		Three-phase AC380~440V -10%~10%		
Control circuit power supply	Single Phase AC200~240V, -15%~10%							Three-phase AC380~440V -10%~10%		

### Model Table

Dimensions	Type A	Type B	Type C	Type D	Type E
Appearance					
Rotary drive model (* represents pulse P or bus N FB in brackets stands for full power Energy type)	ODSA*6A201GB(FB)	ODSA*6A751GB(FB)	ODSA*6A152GB(FB)	ODSA*6A202GB(FB)	ODSA*6B752GB(FB)
	ODSA*6A401GB(FB)	ODSA*6A102GB(FB)	ODSA*6A192GB(FB)	ODSA*6A302GB(FB)	ODSA*6B040GBL
				ODSA*6A402GB	
				ODSA*6B452GB(FB)	
Linear drive models (* represents pulse P or bus N)	ODSA*6A3D2GBL	ODSA*6A5D6GBL	ODSA*6A9D7GBL	ODSA*6A014GBL	
		ODSA*6A007GBL		ODSA*6A021GBL	
				ODSA*6B021GBL	

## Driver side accessories

Driver Specifications	Accessory name (interface code)	Model	Remark
ODSAP6 Specifications	USB debugging cable (CN1)	USB3.0 A TO TYPE C L=1.5M BK	Optional (1.5m)
	IO plug (CN2)	SC-50A-3	Optional
	First encoder plug (CN3)	1394-6P公头	Optional
	Second encoder plug (CN4)	6364-10MSHW5SCB01	Optional
	Brake module (CN5)	BRK-M-1	Optional
	Gantry communication line (CN6)	SC-NT0.2M-5ECS-ZS	Optional (0.2m)
	Modbus communication line	SC-NT1M-5ECS-A1	Optional (1m)
	STO connector (CN8)	1H/C3030HF-2*4P	Factory standard (short-circuited)
	STO connector (CN8)	C3030HF-2*04P+3001PT*10	Optional (including pins, customers can short-circuit by themselves)
	Interface CNA plug (CNA)	SC-T3507505SB0X-04	Factory standard
Interface CNB plug (CNB)	SC-T3507506SB0Y-04	Factory standard	
ODSAN6规格	USB debugging cable (CN1)	USB3.0 A TO TYPE C L=1.5M BK	Optional (1.5m)
	EtherCAT communication cable (CN2-IN)	SC-NT0.2M-5ECS-A1	Optional (0.2m)
	EtherCAT communication cable (CN3-OUT)	SC-NT0.2M-5ECS-A1	Optional (0.2m)
	IO plug (CN4)	SC-26-3P	Optional
	Second encoder (CN5)	6364-10MSHW5SCB01	Optional
	First encoder (CN6)	1394-6P公头	Optional
	Brake module (CN7)	BRK-M-1	Optional
	Gantry communication line (CN8)	SC-NT0.2M-5ECS-ZS	Optional
	STO connector (CN9)	1H/C3030HF-2*4P	Factory standard (short-circuited)
	STO connector (CN9)	C3030HF-2*04P+3001PT*10	Optional (including pins, customers can short-circuit by themselves)
Interface CNA plug (CNA)	SC-T3507505SB0X-04	Factory standard	
Interface CNB plug (CNB)	SC-T3507506SB0Y-04	Factory standard	

Note: Please use the cable model configured by our company as much as possible, otherwise the reliability of communication cannot be guaranteed.

# Ω6-C Series Servo Driver

Accurate and efficient, easy to use,  
power range 100W~1.5kW



## Function Configuration

Function	ODSCP6		ODSCN6	
	Basic Type (B)	Straight line (GBL)	Basic Type (B)	Straight line (GBL)
USB Communication	✓	✓	✓	✓
Modbus	✓	✓		
EtherCAT			✓	✓
Command pulse input	✓	✓		
Encoder frequency division output (ABZ)	✓	✓	✓	✓
Analog voltage input		✓		
High-speed DI		✓		✓
High-speed DO		✓		✓
Probe		✓		✓
Flying Shoot		✓		✓
Positioning compensation	✓	✓	✓	✓
Hall commutation self-learning		✓		✓
Gantry synchronization		✓		

## ODSCP6 Technical Specifications

Technical specifications		Describe
Encoder feedback	Rotary adapter encoder	Serial communication encoder
	Linear adapter encoder	16Mbps ABZ encoder; BiSS C encoder; Serial communication encoder
Conditions of Use	Operating temperature	- 5°C ~ 45°C (no freezing)
	Storage temperature	-20°C ~ 70°C
	Use/Storage Humidity	Below 95%RH (no freezing or condensation)
	Vibration resistance	5.88m/s <sup>2</sup> or less, 10 ~ 60Hz (cannot be used continuously at resonant frequency)
	Impact strength	19.6m/s <sup>2</sup>
	Altitude	Normal use below 1000m, please derate between 1000 ~ 2000m

Technical specifications		Describe		
IO interface connector	Digital signal (linear)	Enter	6 general inputs, 2 of which are high-speed DIs. The function of the general input can be selected according to the parameters.	
		Output	5 general outputs, including 1 high-speed DO, select the function of the general output according to the parameters.	
	Digital signal (rotary type)	Enter	4 universal inputs, select the function of the universal input according to the parameters.	
		Output	4 general outputs, select the function of the general output according to the parameters.	
	analog signal	Enter	2-way 16-bit A/D, ±10V	
	Pulse signal	Enter	2 inputs, differential input maximum 16Mpps, pulse width cannot be less than 62.5ns the maximum input of the optocoupler is 1Mpps, and the pulse width cannot be less than 2us (it can support 5V, 12V and 24V input)	
Output		3 outputs, A, B, Z phase differential output		
Position Control	Vibration control	Up to 3 can be used at the same time		
	V-type vibration damping filter	A maximum of 1 can be used at a time		
	2 Degrees of Freedom	Available		
	Load variation suppression control	Available		
	Flying shooting function	Available		
Speed control	Internal speed command	8 internal speeds can be switched according to control input		
	Zero speed clamp	According to the zero speed clamp input, the internal speed command can be fixed to 0		
	2 Degrees of Freedom	Available		
	Load variation suppression control	Available		
General	Automatic Adjustment	The action instructions from the upper level and the action instructions issued by the installation and debugging software Ω Master are used to drive the motor in this state, the load inertia is estimated and determined in real time, and the gain corresponding to the rigidity setting is automatically set.		
	Frequency division function of feedback pulse	The number of pulses can be set arbitrarily (however, it cannot exceed the number of encoder feedback pulses)		
	Protection function	Hardware Error	Overvoltage, undervoltage, overtemperature, overload, overcurrent, encoder abnormality, etc.	
		Software Errors	Position deviation is too large, command pulse frequency division, EEPROM parameter abnormality, etc.	
Alarm data tracking function	The alarm data history can be referenced			
Torque control	Speed limit function	Speed limit value can be set according to parameters		
	2 Degrees of Freedom	Unavailable		
	Load variation suppression control	Unavailable		
	Feedforward function	Unavailable		
	Friction torque compensation	Unavailable		
	Hybrid vibration suppression function	Unavailable		
	Torque limit switching function	Unavailable		
	Torque saturation protection function	Unavailable		
Single-turn absolute function	Available (when connected to an absolute encoder)			
Vibration control	Unavailable			

# ODSCP6 specification wiring diagram

## A~B type driver wiring diagram

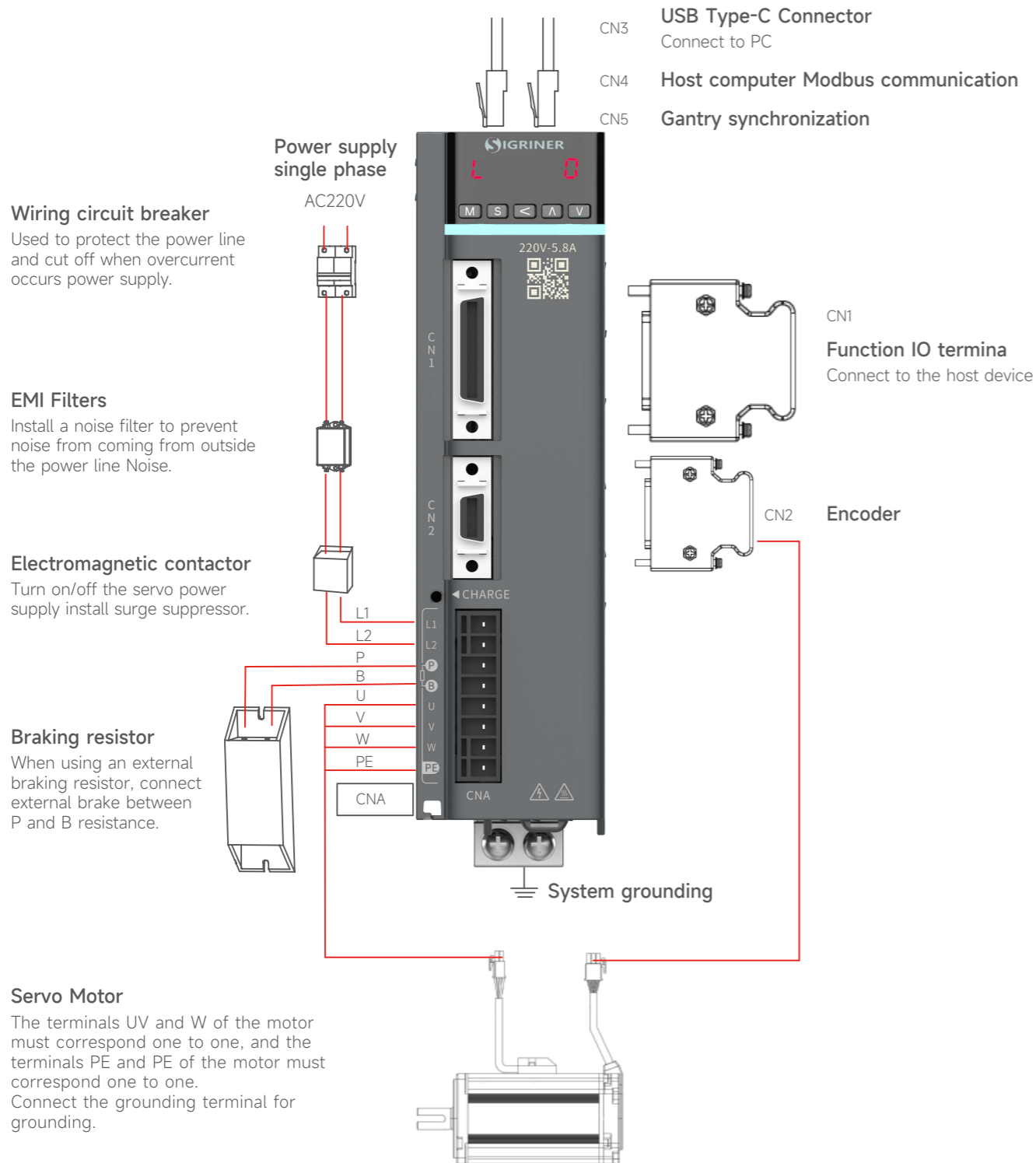

# ODSCN6 Technical Specifications

Technical specification		Describe
Encoder feedback	Rotary adapter encoder	Serial communication encoder;
	Linear adapter encoder	Serial communication encoder; 16Mbps ABZ encoder; BiSS C communication; Hall signal
Conditions of Use	Operating temperature	- 5°C ~ 55°C (no freezing)
	Storage temperature	-20°C ~ 70°C
	Use/Storage Humidity	Below 95%RH (no freezing or condensation)
	Vibration resistance	5.88m/s <sup>2</sup> or less, 10 ~ 60Hz (cannot be used continuously at resonant frequency)
	Impact strength	19.6m/s <sup>2</sup>
	Altitude	Normal use below 1000m, please derate for 1000 ~ 2000m
IO interface connector	Digital signal (linear)	Enter: 6 general inputs, 2 of which are high-speed DIs. The function of the general input can be selected according to the parameters. Output: 5 general outputs, 1 of which is high-speed DO. The function of the general output can be selected according to the parameters.
	Digital signal (rotary type)	Enter: 4 universal inputs, select the function of the universal input according to the parameters Output: 4 general outputs, select the general input function according to the parameters
	Pulse signal	Output: 3-way, differential output of encoder signal or external displacement sensor signal after frequency division processing (A·B phase). The frequency division ratio can be set by parameters and can be used as the position Use for output
Position control	Vibration control	Up to 3 can be used at the same time
	V-type vibration damping filter	A maximum of 1 can be used at a time
	2 Degrees of Freedom	Available
	Load variation suppression control	Available
	Feedforward function	Available (speed/torque)
	3rd gain switching function	Available
	Friction torque compensation	Available
	Quadrant protrusion suppression function	Available
	Torque limit switching function	Available
	Motor movable range setting	Available
	Torque saturation protection function	Available
	Single-turn absolute function	Available (when connected to an absolute encoder)
External displacement sensor position information monitor	Available	

Speed control	2 Degrees of Freedom	Available
	Load variation suppression control	Available
	Feedforward function	Available (torque)
	Friction torque compensation	Available
	Hybrid vibration suppression function	Unavailable
	Torque limit switching function	Available
	Torque saturation protection function	Available
	Single-turn absolute function	Available (when connected to an absolute encoder)
	Vibration contro	Unavailable
	Model damping filter	Unavailable
	3rd gain switching function	Unavailable
	Quadrant protrusion suppression function	Unavailable
	Motor movable range setting	Unavailable
	External displacement sensor position information monitor	Available
Lock mode with stop function	Unavailable	
General	Automatic Adjustment	The motor is driven by the action command from the upper level and the action command issued by the installation and debugging software Ω Master In the state, the load inertia is estimated and determined in real time, and the gain corresponding to the rigidity setting is automatically set.
	Electronic gear ratio setting	1/1000 ~ 1000 times Numerator = 1 ~ 2 <sup>30</sup> , Denominator = 1 ~ 2 <sup>30</sup> can be set arbitrarily Use within the above range.
	Notch filter	5 (2 automatic)
	Gain switching function	Available
	2-stage torque filter	Available
	Position comparison output function	Available
	Protection function	Hardware Error Overvoltage, undervoltage, overtemperature, overload, overcurrent, encoder abnormality, etc. Software Errors Position deviation is too large, command pulse frequency division, EEPROM abnormality, etc.
Alarm data tracking function	You can refer to the history of alarm data	

## ODSCN6 specification wiring diagram

### A~B type driver wiring diagram

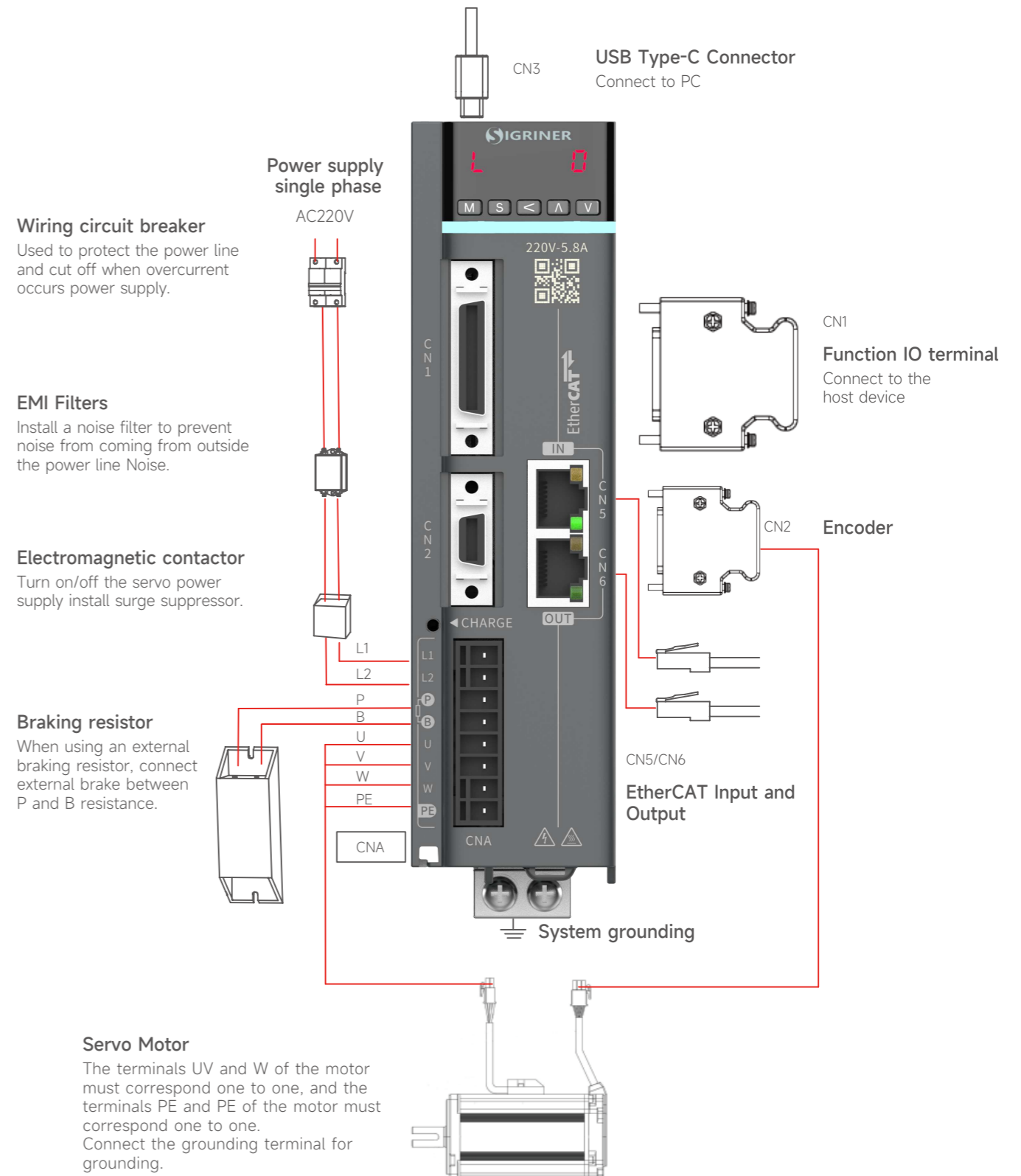



## Electrical specifications and model table

### Electrical specifications

Rotary drive			
Voltage level	220V		
Power (kW)	0.4	0.75	1.5
Rated current (Arms)	2.8	5.0	8.2
Maximum output current (Arms)	9.8	15	21
Dimensions	Type A		Type B
Main circuit power supply	Single-phase AC200~240V, -15%~10%		

Linear drives			
Voltage level	220V		
Model code	3D2	5D8	8D2
Continuous operating current (Arms)	3.2	5.8	8.2
Maximum output current (Arms)	9.8	15	21
Dimensions	Type A		Type B
Main circuit power supply	Single-phase AC200~240V, -15%~10%		

### Model Table

Dimensions	Type A	Type B
Appearance		
Rotary servo models (* represents pulse P or Bus N)	ODSC*6A401BB ODSC*6A751BB	ODSC*6A152BB
Linear Servo Models (* represents pulse P or Bus N)	ODSC*6A3D2GBL ODSC*6A5D8GBL	ODSC*6A8D2GBL

## Driver side accessories

Driver Specifications	Accessory name (interface code)	model	Remark
ODSCP6 Specifications	IO plug (CN1)	SM-SCSI-36P	Optional
	Encoder plug (CN2)	SM-SCSI-14P	Optional
	Interface CNA plug (CNA)	SC-T3005008SBOX	Factory standard
	USB debugging cable (CN3)	USB3.0 A TO TYPE C L=1.5M BK	Optional (1.5m)
	Modbus communication cable (CN4)	SC-NT1M-5ECS-A1	Optional (1m)
	Gantry synchronous communication line (CN5)	SC-NTA02M-G5ECS-M3	Optional (0.2m)
ODSCN6 Specifications	IO plug (CN1)	SM-SCSI-36P	Optional
	Encoder plug (CN2)	SM-SCSI-14P	Optional
	Interface CNA plug (CNA)	SC-T3005008SBOX	Factory standard
	USB debugging cable (CN3)	USB3.0 A TO TYPE C L=1.5M BK	Optional (1.5m)
	EtherCAT communication cable (CN5)	SC-NT0.2M-5ECS-A1	Optional (0.2m)
	EtherCAT communication cable (CN6)	SC-NT0.2M-5ECS-A1	Optional (0.2m)

Note: Please use the cable model configured by our company as much as possible, otherwise the reliability of communication cannot be guaranteed.

## Ω6-W series dual-axis servo drive

Synchronous drive, convenient debugging, extreme size



## Function Configuration

Function	ODMWP6		ODMWN6	
	Basic Type (B)	Linear type (GBL)	Basic Type (B)	Linear type (GBL)
USB Communication	✓	✓	✓	✓
EtherCAT			✓	✓
Modbus	✓	✓		
Command pulse input	✓	✓		
Encoder frequency division output (ABZ)	✓	✓	✓	✓
Probe (slow speed)			✓	✓
Flying shot (slow speed)	✓	✓	✓	✓
Positioning compensation	✓	✓	✓	✓
Gantry synchronization	✓	✓	✓	✓

## ODMWP6 Technical Specifications

Technical specifications	Describe		
Encoder feedback	Rotary adapter encoder	Serial communication encoder	
	Linear adapter encoder	Serial communication encoder; 16Mbps ABZ encoder	
Conditions of Use	Operating temperature	0°C ~ 40°C (no freezing)	
	Storage temperature	-20°C ~ 70°C	
	Operating/Storage Humidity	Below 95%RH (no freezing or condensation)	
	Vibration resistance	5.88m/s <sup>2</sup> or less, 10 ~ 60Hz(Cannot be used continuously at resonant frequency)	
	Impact strength	19.6m/s <sup>2</sup>	
IO interface connector	Altitude	Normal use below 1000m, please derate between 1000m and 2000m	
	Digital Signal	Enter	10 universal inputs (5 inputs per axis) Select the function of the universal input according to the parameters
		Output	6 general outputs (3 outputs per axis) Select the function of the general input according to the parameters
Pulse signal	Enter	2 inputs, differential input maximum 16Mpps, pulse width cannot be less than 62.5ns the maximum input of the optocoupler is 1Mpps, and the pulse width cannot be less than 2us (it can support 5V, 12V and 24V input)	
	Output	3 outputs, A, B, Z frequency division output	



# ODMWP6 specification wiring diagram

## A~B type driver wiring diagram

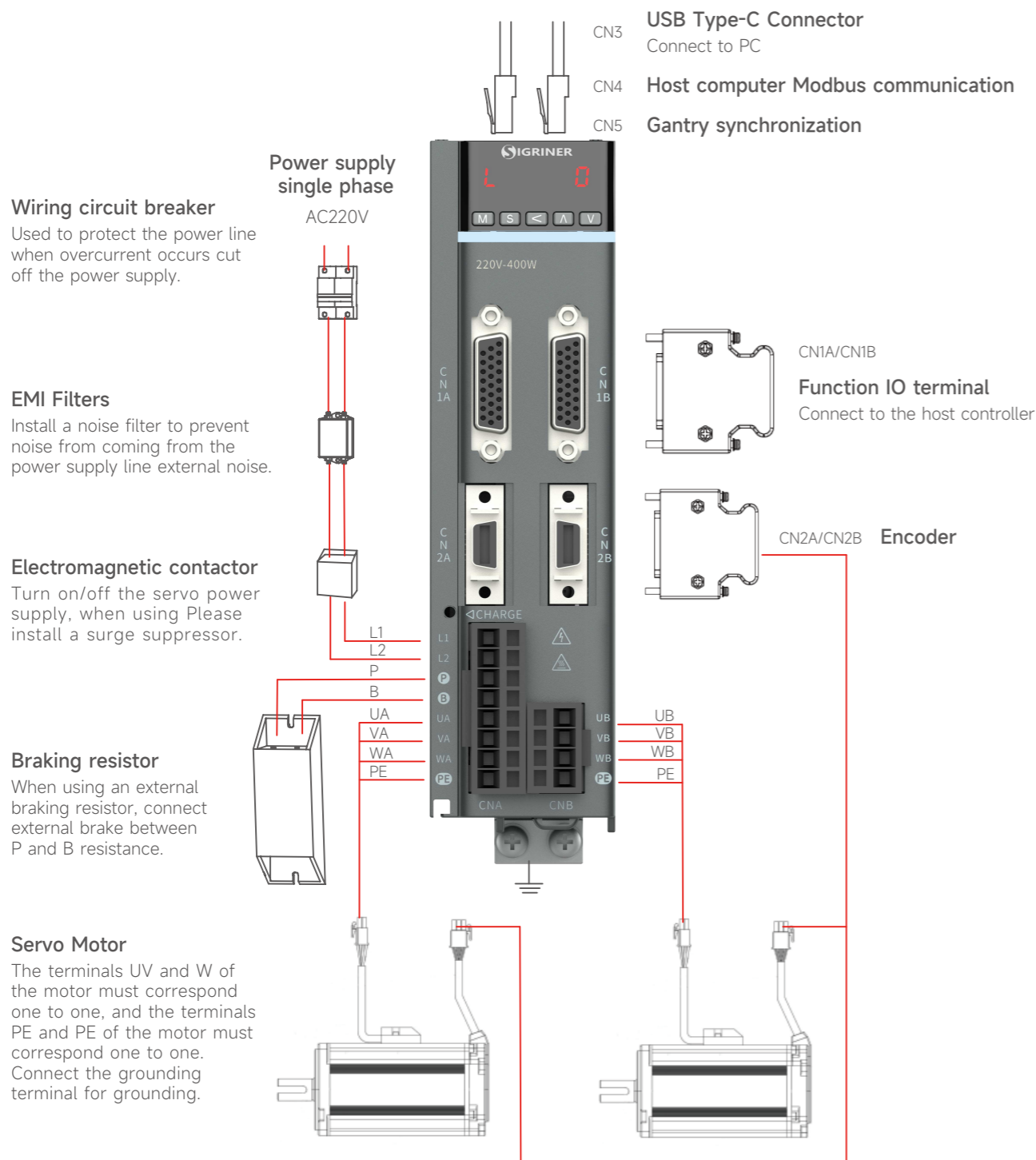

# ODMWN6 Technical Specifications

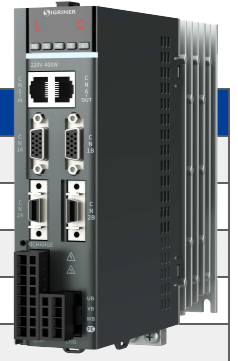

Technical specifications		Describe	
Encoder feedback	Rotary adapter encoder	Serial communication encoder	
	Linear adapter encoder	Serial communication encoder; 16Mbps ABZ encoder	
Conditions of Use	Operating temperature	0°C ~ 40°C (no freezing)	
	Storage temperature	-20°C ~ 70°C	
	Operating/Storage Humidity	Below 95%RH (no freezing or condensation)	
	Vibration resistance	5.88m/s <sup>2</sup> or less, 10 ~ 60Hz (Cannot be used continuously at resonant frequency)	
	Impact strength	19.6m/s <sup>2</sup>	
	Altitude	Normal use below 1000m, please derate for 1000m ~ 2000m	
IO interface connector	Digital Signal	Enter	6 universal inputs (3 inputs per axis), select the function of the universal input according to the parameters
		Output	4 general outputs (2 outputs per axis), select the general input function according to the parameters
	Pulse signal	Output	3 outputs, A, B, Z frequency division output
General	Friction torque compensation	Available	
	Torque limit switching function	Available	
	Torque saturation protection function	Available	
	Single-turn absolute function	Available (when connected to an absolute encoder)	
	Automatic Adjustment	The action instructions from the upper level and the action instructions issued by the installation and debugging software Ω Master are driven by the motor in this state, the load inertia is estimated and determined in real time, and the gain corresponding to the rigidity setting is automatically set.	
	Electronic gear ratio setting	1/1000 ~ 1000 times Numerator = 1 ~ 2 <sup>30</sup> , Denominator = 1 ~ 2 <sup>30</sup> can be set arbitrarily, Please use within the above range.	
	Notch filter	5 (2 automatic)	
	Gain switching function	Available	
	2-stage torque filter	Available	
	Position comparison output function	Available	
	Protection function	Hardware Error	Overvoltage, undervoltage, overtemperature, overload, overcurrent, encoder abnormality, etc.
		Software Errors	Position deviation is too large, command pulse frequency division, EEPROM abnormality, etc.
	Alarm data tracking function	The alarm data history can be referenced	

# ODMWN6 specification wiring diagram

## A~B type driver wiring diagram

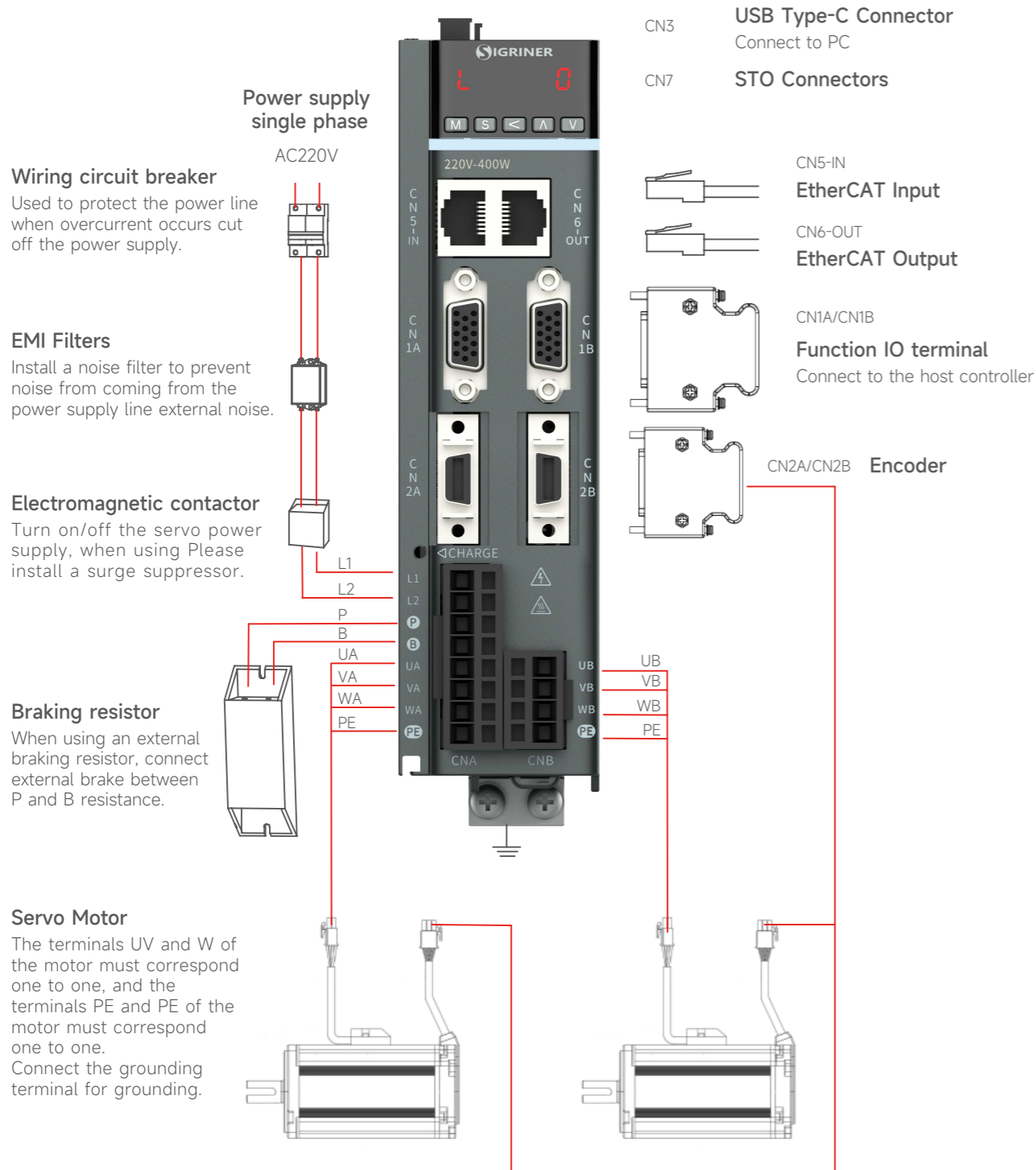

# Electrical specifications and model table

## Model Table

Dimensions	Type A	Type B
Appearance		
Rotary servo models	ODMW*6A44BB	ODMW*6A77BB
Linear servo models	ODMW*6A44GBL	ODMW*6A77GBL

## Electrical specifications

Rotary drive		
Voltage level	220V	
Model code	ODMW*6A44BB	ODMW*6A77BB
Power (kW)	0.4	0.75
Rated current (Arms)	2.8	5.0
Maximum output current (Arms)	9.8	15
Dimensions	Type A	Type B
Main circuit power supply	Single-phase AC200~240V, -15%~10%	

Linear drives		
Voltage level	220V	
Model code	ODMW*6A44GBL	ODMW*6A77GBL
Rated current (Arms)	3.2	5.8
Maximum output current (Arms)	9.8	15
Dimensions	Type A	Type B
Main circuit power supply	Single-phase AC200~240V, -15%~10%	

## Driver side accessories

Driver Specifications	Accessory name (interface code)	Model	Remark
ODMWP6 Specifications	Plug CNA (CNA)	SC-T3005008SBOX	Factory standard
	Plug CNB (CNB)	SC-T3005004SBOX	Factory standard
	IO plug (CN1A)	1167-026-101-000-RC	Optiona
	IO plug (CN1B)	1185-015-105-RC	
	Encoder plug (CN2A)	SM-SCSI-14P	Optiona
	Encoder plug (CN2B)	SM-SCSI-14P	Optiona
ODMWN6 Specifications	USB debugging cable (CN3)	USB3.0 A TO TYPE C L=1.5M BK	Optional (1.5m)
	Modbus communication cable (CN4)	SC-NT1M-5ECS-A1	Optional (1m)
	IO plug (CN1A)	YZMHDB150301	Optiona
	IO plug (CN1B)	1185-009-105-RC	
	Encoder interface (CN2A)	SM-SCSI-14P	Optiona
	Encoder interface (CN2B)	SM-SCSI-14P	Optiona
	Plug CNA (CNA)	SC-T3005008SBOX	Factory standard
	Plug CNB (CNB)	SC-T3005004SBOX	Factory standard
	EntherCAT communication cable (CN5-IN)	SC-NT0.2M-5ECS-A1	Optional (0.2m)
	EntherCAT communication cable (CN6-OUT)	SC-NT0.2M-5ECS-A1	Optional (0.2m)
	USB debugging cable (CN3)	USB3.0 A TO TYPE C L=1.5M BK	Optional (1.5m)
	STO interface (CN7)	1H/C3030HF-2*4P	Factory standard (short-circuited)
	STO interface (CN7)	C3030HF-2*04P+3001PT*10	Optional (including pins, customers can short-circuit by themselves)

Note: Please use the cable model configured by our company as much as possible, otherwise the reliability of communication cannot be guaranteed.

## OMP Series Motors

### Naming convention

OMP	06	M	401	N	2	L	C1	**
1-3	4-5	6	7-9	10	11	12	13	14-15

<b>1-3 Product Series</b>	OMP: OMP series servo motors	<b>11 Voltage level</b>	2: 220V 4: 380V
<b>4-5 Flange</b>	04: 40 Flange	<b>12 Shaft/Oil Seal</b>	S: Straight shaft without oil seal K: Key shaft without oil seal T: Straight shaft with oil seal L: Key shaft has oil seal (commonly used)
	06: 60 Flange		
	08: 80 Flange		
	.....		
<b>6 Inertia Type</b>	M: Medium inertia H: High Inertia	<b>13 Encoder Type</b>	C1: 20bit absolute value (magnetic encoding) C2: 23bit absolute value (optical encoding) C3: 25bit absolute value (optical encoding)
<b>7-9 Motor power</b>	101: 100W		
	201: 200W		
	401: 400W		
	751: 750W		
<b>10 Brakes</b>	N: No brake	<b>** Special specifications</b>	Space: 40/60/80 flange is a strip type, 100 flange and above are aviation plugs. - 1: 40/60/80 flange is a drop-line model
	A: With brake		

### Motor performance parameters

#### (1) AC220V 40/60/80 flange motor [plug-in type]

Model	Rated Power (W)	Rated torque (N.m)	Maximum torque (N.m)	Rated current (A)	Maximum current (A)	Rated speed (r/min)	Maximum speed (r/min)	Torque coefficient (N.m/A)	Rotor inertia (10 <sup>-4</sup> )kg.m <sup>2</sup>	Brake/non-brake
20-bit magnetic motor										
OMP04M101N2LC1	100	0.32	0.96	1.1	3.9	3000	6000	0.29	0.071	Non-brake
OMP04M101A2LC1									0.074	Holding brake
OMP06M201N2LC1	200	0.64	2.23	2.2	7.7	3000	6000	0.289	0.16	Non-brake
OMP06M201A2LC1									0.22	Holding brake
OMP06M401N2LC1	400	1.27	4.46	2.9	10.2	3000	6000	0.439	0.45	Non-brake
OMP06M401A2LC1									0.47	Holding brake
OMP08M751N2LC1	750	2.39	8.36	5	17.5	3000	6000	0.478	1.33	Non-brake
OMP08M751A2LC1									1.49	Holding brake
OMP08M102N2LC1	1000	3.18	9.55	6.9	20.7	3000	6000	0.461	1.58	Non-brake
OMP08M102A2LC1									1.71	Holding brake
23-bit optical encoder motor										
OMP04M101N2LC2	100	0.32	0.96	1.1	3.9	3000	6000	0.29	0.071	Non-brake
OMP04M101A2LC2									0.074	Holding brake
OMP06M201N2LC2	200	0.64	2.23	2.2	7.7	3000	6000	0.289	0.16	Non-brake
OMP06M201A2LC2									0.22	Holding brake

Model	Rated Power (W)	Rated torque (N.m)	Maximum torque (N.m)	Rated current (A)	Maximum current (A)	Rated speed (r/min)	Maximum speed (r/min)	Torque coefficient (N.m/A)	Rotor inertia (10 <sup>-4</sup> )kg.m <sup>2</sup>	Brake/non-brake
OMP06M401N2LC2	400	1.27	4.46	2.9	10.2	3000	6000	0.439	0.45	Non-brake
OMP06M401A2LC2									0.47	Holding brake
OMP08M751N2LC2	750	2.39	8.36	5	17.5	3000	6000	0.478	1.33	Non-brake
OMP08M751A2LC2									1.49	Holding brake
OMP08M102N2LC2	1000	3.18	9.55	6.9	20.7	3000	6000	0.461	1.58	Non-brake
OMP08M102A2LC2									1.71	Holding brake
25-bit optical encoder motor										
OMP04M101N2LC3	100	0.32	0.96	1.1	3.9	3000	6000	0.29	0.071	Non-brake
OMP04M101A2LC3									0.074	Holding brake
OMP06M201N2LC3	200	0.64	2.23	2.2	7.7	3000	6000	0.289	0.16	Non-brake
OMP06M201A2LC3									0.22	Holding brake
OMP06M401N2LC3	400	1.27	4.46	2.9	10.2	3000	6000	0.439	0.45	Non-brake
OMP06M401A2LC3									0.47	Holding brake
OMP08M751N2LC3	750	2.39	8.36	5	17.5	3000	6000	0.478	1.33	Non-brake
OMP08M751A2LC3									1.49	Holding brake
OMP08M102N2LC3	1000	3.18	9.55	6.9	20.7	3000	6000	0.461	1.58	Non-brake
OMP08M102A2LC3									1.71	Holding brake

#### (2) AC220V 40/60/80 flange motor [drop wire type]

Model	Rated Power (W)	Rated torque (N.m)	Maximum torque (N.m)	Rated current (A)	Maximum current (A)	Rated speed (r/min)	Maximum speed (r/min)	Torque coefficient (N.m/A)	Rotor inertia (10 <sup>-4</sup> )kg.m <sup>2</sup>	Brake/non-brake
20-bit magnetic motor										
OMP04M101N2LC1-1	100	0.32	0.96	1.1	3.9	3000	6000	0.29	0.071	Non-brake
OMP04M101A2LC1-1									0.074	Holding brake
OMP06M201N2LC1-1	200	0.64	2.23	2.2	7.7	3000	6000	0.289	0.16	Non-brake
OMP06M201A2LC1-1									0.22	Holding brake
OMP06M401N2LC1-1	400	1.27	4.46	2.9	10.2	3000	6000	0.439	0.45	Non-brake
OMP06M401A2LC1-1									0.47	Holding brake
OMP08M751N2LC1-1	750	2.39	8.36	5	17.5	3000	6000	0.478	1.33	Non-brake
OMP08M751A2LC1-1									1.49	Holding brake
OMP08M102N2LC1-1	1000	3.18	9.55	6.9	20.7	3000	6000	0.461	1.58	Non-brake
OMP08M102A2LC1-1									1.71	Holding brake
23-bit optical encoder motor										
OMP04M101N2LC2-1	100	0.32	0.96	1.1	3.9	3000	6000	0.29	0.071	Non-brake
OMP04M101A2LC2-1									0.074	Holding brake
OMP06M201N2LC2-1	200	0.64	2.23	2.2	7.7	3000	6000	0.289	0.16	Non-brake
OMP06M201A2LC2-1									0.22	Holding brake
OMP06M401N2LC2-1	400	1.27	4.46	2.9	10.2	3000	6000	0.439	0.45	Non-brake
OMP06M401A2LC2-1									0.47	Holding brake
OMP08M751N2LC2-1	750	2.39	8.36	5	17.5	3000	6000	0.478	1.33	Non-brake
OMP08M751A2LC2-1									1.49	Holding brake
OMP08M102N2LC2-1	1000	3.18	9.55	6.9	20.7	3000	6000	0.461	1.58	Non-brake
OMP08M102A2LC2-1									1.71	Holding brake

Model	Rated Power (W)	Rated torque (N.m)	Maximum torque (N.m)	Rated current (A)	Maximum current (A)	Rated speed (r/min)	Maximum speed (r/min)	Torque coefficient (N.m/A)	Rotor inertia (10 <sup>^-4</sup> )kg.m <sup>^2</sup>	Brake/non-brake
25-bit optical encoder motor										
OMP04M101N2LC3-1	100	0.32	0.96	1.1	3.9	3000	6000	0.29	0.071	Non-brake
OMP04M101A2LC3-1									0.074	Holding brake
OMP06M201N2LC3-1	200	0.64	2.23	2.2	7.7	3000	6000	0.289	0.16	Non-brake
OMP06M201A2LC3-1									0.22	Holding brake
OMP06M401N2LC3-1	400	1.27	4.46	2.9	10.2	3000	6000	0.439	0.45	Non-brake
OMP06M401A2LC3-1									0.47	Holding brake
OMP08M751N2LC3-1	750	2.39	8.36	5	17.5	3000	6000	0.478	1.33	Non-brake
OMP08M751A2LC3-1									1.49	Holding brake
OMP08M102N2LC3-1	1000	3.18	9.55	6.9	20.7	3000	6000	0.461	1.58	Non-brake
OMP08M102A2LC3-1									1.71	Holding brake

### (3) AC220V 100 flange motor

Model	Rated Power (W)	Rated torque (N.m)	Maximum torque (N.m)	Rated current (A)	Maximum current (A)	Rated speed (r/min)	Maximum speed (r/min)	Torque coefficient (N.m/A)	Rotor inertia (10 <sup>^-4</sup> )kg.m <sup>^2</sup>	Brake/non-brake
23-bit optical encoder motor										
OMP10M102N2LC2	1000	3.2	9.6	7	21	3000	6000	0.45	2.458	Non-brake
OMP10M102A2LC2									3.042	Holding brake
OMP10M152N2LC2	1500	4.77	14.3	8.9	26.7	3000	5000	0.53	3.659	Non-brake
OMP10M152A2LC2									4.243	Holding brake
25-bit optical encoder motor										
OMP10M102N2LC3	1000	3.18	9.55	9.3	27.9	3000	6000	0.34	1.52	Non-brake
OMP10M102A2LC3									1.78	Holding brake
OMP10M152N2LC3	1500	4.77	14.32	8.7	26	3000	5000	0.55	2.07	Non-brake
OMP10M152A2LC3									2.33	Holding brake
OMP10M202N2LC3	2000	6.37	19.1	11.3	33.9	3000	5000	0.56	2.69	Non-brake
OMP10M202A2LC3									2.95	Holding brake
OMP10M252N2LC3	2500	7.96	23.87	13.6	40.8	3000	5000	0.59	4.37	Non-brake
OMP10M252A2LC3									4.55	Holding brake

### (4) AC220V 130 flange motor

Model	Rated Power (W)	Rated torque (N.m)	Maximum torque (N.m)	Rated current (A)	Maximum current (A)	Rated speed (r/min)	Maximum speed (r/min)	Torque coefficient (N.m/A)	Rotor inertia (10 <sup>^-4</sup> )kg.m <sup>^2</sup>	Brake/non-brake
23-bit optical encoder motor										
OMP13M851N2L2	850	1500	3000	6.9	18.1	1500	3000	0.78	13.9	Non-brake
OMP13M851A2L2									18.1	Holding brake
OMP13M132N2L2	1300	8.34	23.3	10.7	29.9	1500	3000	0.78	19.9	Non-brake
OMP13M132A2L2									-	Holding brake
OMP13M102N2L2	1000	4.77	14.3	5.5	16.5	2000	3000	-	7.35	Non-brake
OMP13M102A2L2									8.55	Holding brake
OMP13M152N2L2	1500	7.16	21.5	7.9	23.7	2000	3000	-	10.5	Non-brake
OMP13M152A2L2									11.7	Holding brake
25-bit optical encoder motor										
OMP13M851N2L3	850	5.41	16.23	5.8	17.5	1500	3000	0.926	3.78	Non-brake
OMP13M851A2L3									5.68	Holding brake

Model	Rated Power (W)	Rated torque (N.m)	Maximum torque (N.m)	Rated current (A)	Maximum current (A)	Rated speed (r/min)	Maximum speed (r/min)	Torque coefficient (N.m/A)	Rotor inertia (10 <sup>^-4</sup> )kg.m <sup>^2</sup>	Brake/non-brake
OMP13M132N2L3	1300	8.28	24.83	9.5	28.4	1500	3000	0.873	4.5	Non-brake
OMP13M132A2L3									6.4	Holding brake
OMP13M182N2L3	1800	11.46	34.38	11.5	34.4	1500	3000	1	6.2	Non-brake
OMP13M182A2L3									8	Holding brake
OMP13M102N2L3	1000	4.77	14.32	5	14.9	2000	3000	0.959	3.78	Non-brake
OMP13M102A2L3									5.68	Holding brake
OMP13M152N2L3	1500	7.16	21.49	8.2	24.6	2000	3000	0.87	4.5	Non-brake
OMP13M152A2L3									6.4	Holding brake
OMP13M202N2L3	2000	9.55	28.65	9.5	28.5	2000	3000	1	6.2	Non-brake
OMP13M202A2L3									8	Holding brake
OMP13M302N2L3	3000	14.32	42.97	17.4	52.2	2000	3000	0.823	8.51	Non-brake
OMP13M302A2L3									10.34	Holding brake
OMP13H402N2L3	4000	12.73	38.2	22.8	68.4	3000	5000	0.558	26.17	Non-brake
OMP13H402A2L3									28	Holding brake

### (5) AC380V 100 flange motor

Model	Rated Power (W)	Rated torque (N.m)	Maximum torque (N.m)	Rated current (A)	Maximum current (A)	Rated speed (r/min)	Maximum speed (r/min)	Torque coefficient (N.m/A)	Rotor inertia (10 <sup>^-4</sup> )kg.m <sup>^2</sup>	Brake/non-brake
25-bit optical encoder motor										
OMP10M102N4L3	1000	3.18	9.55	4.5	13.5	3000	6000	0.707	1.52	Non-brake
OMP10M102A4L3									1.78	Holding brake
OMP10M152N4L3	1500	4.77	14.32	5.4	16.3	3000	5000	0.879	2.07	Non-brake
OMP10M152A4L3									2.33	Holding brake
OMP10M202N4L3	2000	6.37	19.1	6.8	20.4	3000	5000	0.936	2.69	Non-brake
OMP10M202A4L3									2.95	Holding brake
OMP10M252N4L3	2500	7.96	23.87	8.8	26.4	3000	5000	0.904	3.6	Non-brake
OMP10M252A4L3									3.86	Holding brake

### (6) AC380V 130 flange motor

Model	Rated Power (W)	Rated torque (N.m)	Maximum torque (N.m)	Rated current (A)	Maximum current (A)	Rated speed (r/min)	Maximum speed (r/min)	Torque coefficient (N.m/A)	Rotor inertia (10 <sup>^-4</sup> )kg.m <sup>^2</sup>	Brake/non-brake
25位光编电机										
OMP13H132N4L3	1300	8.28	24.83	6.7	20.1	1500	3000	1.235	19.17	非抱闸
OMP13H132A4L3									21.07	抱闸
OMP13H182N4L3	1800	11.46	34.38	8.6	25.8	1500	3000	1.332	20.9	非抱闸
OMP13H182A4L3									22.8	抱闸
OMP13M102N4L3	1000	4.77	14.32	5	14.9	2000	3000	0.959	3.78	非抱闸
OMP13M102A4L3									5.68	抱闸
OMP13M152N4L3	1500	7.16	21.49	8.2	24.6	2000	3000	0.87	4.5	非抱闸
OMP13M152A4L3									6.4	抱闸
OMP13M202N4L3	2000	9.55	28.65	9.5	28.5	2000	3000	1	6.2	非抱闸
OMP13M202A4L3									8	抱闸
OMP13M302N4L3	3000	14.32	42.97	17.4	52.2	2000	3000	0.823	8.51	非抱闸
OMP13M302A4L3									10.34	抱闸
OMP13H402N4L3	4000	12.73	38.2	22.8	68.4	3000	5000	0.558	26.17	非抱闸
OMP13H402A4L3									28	抱闸

(7) AC380V 180 flange motor

Model	Rated Power (W)	Rated torque (N.m)	Maximum torque (N.m)	Rated current (A)	Maximum current (A)	Rated speed (r/min)	Maximum speed (r/min)	Torque coefficient (N.m/A)	Rotor inertia (10 <sup>-4</sup> kg.m <sup>2</sup> )	Brake/non-brake
25-bit optical encoder motor										
OMP18M292N4L3	2900	18.46	55.39	11	33	1500	3000	1.678	40.02	Non-brake
OMP18M292A4L3									59.3	Holding brake
OMP18M452N4L3	4500	28.65	85.94	15.3	45.9	1500	3000	1.872	63.44	Non-brake
OMP18M452A4L3									75	Holding brake
OMP18M552N4L3	5500	35.01	105.04	19.3	57.9	1500	3000	1.814	93.73	Non-brake
OMP18M552A4L3									98.93	Holding brake
OMP18M752N4L3	7500	47.75	143.24	27.4	82.1	1500	3000	1.746	143.9	Non-brake
OMP18M752A4L3									148.2	Holding brake

Motor size parameters

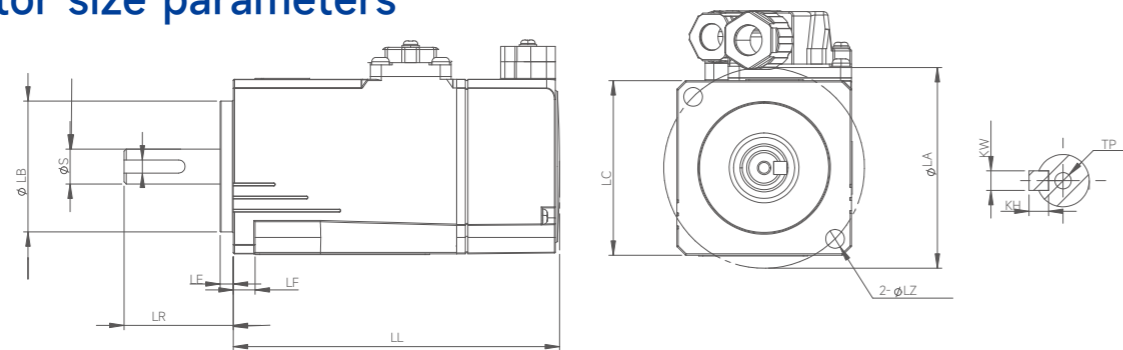

(1) AC220V 40/60/80 flange motor [plug-in type]

Model	LC(mm)	LE(mm)	LF(mm)	LA(mm)	LZ(mm)	S(mm)	LB(mm)	LR(mm)	LL(mm)	Brake/non-brake
20-bit magnetic motor										
OMP04M101N2LC1	40	3	5	46	4.3	8	30	25	75	Non-brake
OMP04M101A2LC1									103.9	Holding brake
OMP06M201N2LC1	60	3	6	70	5.5	14	50	30	67	Non-brake
OMP06M201A2LC1									91	Holding brake
OMP06M401N2LC1	60	3	6	70	5.5	14	50	30	84.8	Non-brake
OMP06M401A2LC1									108.7	Holding brake
OMP08M751N2LC1	80	3	8	90	7	19	70	35	90.9	Non-brake
OMP08M751A2LC1									119.5	Holding brake
OMP08M102N2LC1	80	3	8	90	7	19	70	35	98.9	Non-brake
OMP08M102A2LC1									127.5	Holding brake
23-bit optical encoder motor										
OMP04M101N2LC2	40	3	5	46	4.3	8	30	25	75	Non-brake
OMP04M101A2LC2									103.9	Holding brake
OMP06M201N2LC2	60	3	6	70	5.5	14	50	30	67	Non-brake
OMP06M201A2LC1									91	Holding brake
OMP06M401N2LC2	60	3	6	70	5.5	14	50	30	84.8	Non-brake
OMP06M401A2LC2									108.7	Holding brake
OMP08M751N2LC2	80	3	8	90	7	19	70	35	90.9	Non-brake
OMP08M751A2LC2									119.5	Holding brake
OMP08M102N2LC2	80	3	8	90	7	19	70	35	98.9	Non-brake
OMP08M102A2LC2									127.5	Holding brake

Model	LC(mm)	LE(mm)	LF(mm)	LA(mm)	LZ(mm)	S(mm)	LB(mm)	LR(mm)	LL(mm)	Brake/non-brake
25-bit optical encoder motor										
OMP04M101N2LC3	40	3	5	46	4.3	8	30	25	75	Non-brake
OMP04M101A2LC3									103.9	Holding brake
OMP06M201N2LC3	60	3	6	70	5.5	14	50	30	67	Non-brake
OMP06M201A2LC3									91	Holding brake
OMP06M401N2LC3	60	3	6	70	5.5	14	50	30	84.8	Non-brake
OMP06M401A2LC3									108.7	Holding brake
OMP08M751N2LC3	80	3	8	90	7	19	70	35	90.9	Non-brake
OMP08M751A2LC3									119.5	Holding brake
OMP08M102N2LC3	80	3	8	90	7	19	70	35	98.9	Non-brake
OMP08M102A2LC3									127.5	Holding brake

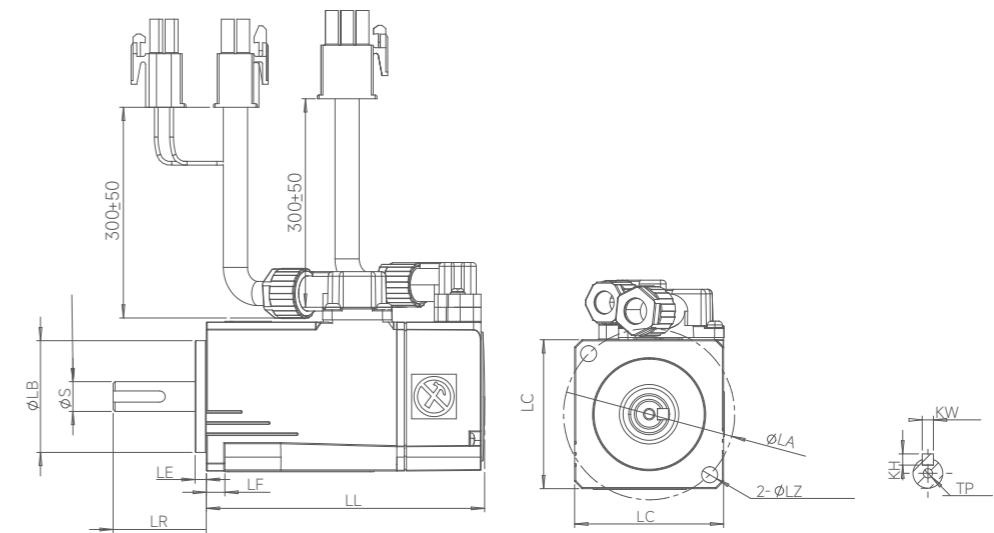

(2) AC220V 40/60/80 flange motor [drop wire type]

Model	LC(mm)	LE(mm)	LF(mm)	LA(mm)	LZ(mm)	S(mm)	LB(mm)	LR(mm)	LL(mm)	Brake/non-brake
20-bit magnetic motor										
OMP04M101N2LC1-1	40	3	5	46	4.3	8	30	25	75	Non-brake
OMP04M101A2LC1-1									103.9	Holding brake
OMP06M201N2LC1-1	60	3	6	70	5.5	14	50	30	67	Non-brake
OMP06M201A2LC1-1									91	Holding brake
OMP06M401N2LC1-1	60	3	6	70	5.5	14	50	30	84.8	Non-brake
OMP06M401A2LC1-1									108.7	Holding brake
OMP08M751N2LC1-1	80	3	8	90	7	19	70	35	90.9	Non-brake
OMP08M751A2LC1-1									119.5	Holding brake
OMP08M102N2LC1-1	80	3	8	90	7	19	70	35	98.9	Non-brake
OMP08M102A2LC1-1									127.5	Holding brake

Model	LC(mm)	LE(mm)	LF(mm)	LA(mm)	LZ(mm)	S(mm)	LB(mm)	LR(mm)	LL(mm)	Brake/non-brake
23-bit optical encoder motor										
OMP04M101N2LC2-1	40	3	5	46	4.3	8	30	25	75	Non-brake
OMP04M101A2LC2-1									103.9	Holding brake
OMP06M201N2LC2-1	60	3	6	70	5.5	14	50	30	67	Non-brake
OMP06M201A2LC2-1									91	Holding brake
OMP06M401N2LC2-1	60	3	6	70	5.5	14	50	30	84.8	Non-brake
OMP06M401A2LC2-1									108.7	Holding brake
OMP08M751N2LC2-1	80	3	8	90	7	19	70	35	90.9	Non-brake
OMP08M751A2LC2-1									119.5	Holding brake
OMP08M102N2LC2-1	80	3	8	90	7	19	70	35	98.9	Non-brake
OMP08M102A2LC2-1									127.5	Holding brake
25-bit optical encoder motor										
OMP04M101N2LC3-1	40	3	5	46	4.3	8	30	25	75	Non-brake
OMP04M101A2LC3-1									103.9	Holding brake
OMP06M201N2LC3-1	60	3	6	70	5.5	14	50	30	67	Non-brake
OMP06M201A2LC3-1									91	Holding brake
OMP06M401N2LC3-1	60	3	6	70	5.5	14	50	30	84.8	Non-brake
OMP06M401A2LC3-1									108.7	Holding brake
OMP08M751N2LC3-1	80	3	8	90	7	19	70	35	90.9	Non-brake
OMP08M751A2LC3-1									119.5	Holding brake
OMP08M102N2LC3-1	80	3	8	90	7	19	70	35	98.9	Non-brake
OMP08M102A2LC3-1									127.5	Holding brake

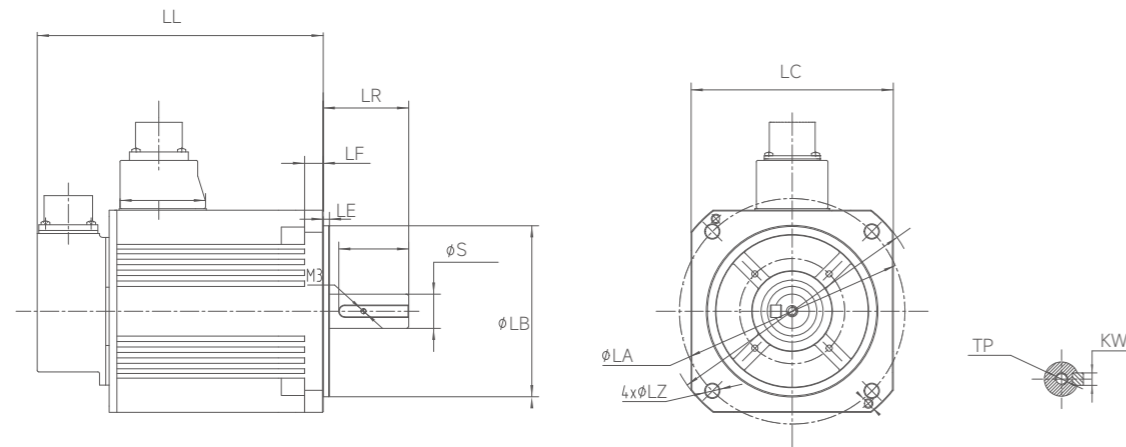

### (3) AC220V 100 flange motor

Model	LC(mm)	LE(mm)	LF(mm)	LA(mm)	LZ(mm)	S(mm)	LB(mm)	LR(mm)	LL(mm)	Brake/non-brake
23-bit optical encoder motor										
OMP10M102N2LC2	100	3	14	115	9	24	95	45	153	Non-brake
OMP10M102A2LC2									194	Holding brake
OMP10M152N2LC2	100	3	14	115	9	24	95	45	175	Non-brake
OMP10M152A2LC2									216	Holding brake

Model	LC(mm)	LE(mm)	LF(mm)	LA(mm)	LZ(mm)	S(mm)	LB(mm)	LR(mm)	LL(mm)	Brake/non-brake
25-bit optical encoder motor										
OMP10M102N2LC3	100	3	13	115	9	24	95	45	142.2	Non-brake
OMP10M102A2LC3									180.3	Holding brake
OMP10M152N2LC3	100	3	13	115	9	24	95	45	142.2	Non-brake
OMP10M152A2LC3									180.3	Holding brake
OMP10M202N2LC3	100	3	13	115	9	24	95	45	162.2	Non-brake
OMP10M202A2LC3									200.3	Holding brake
OMP10M252N2LC3	100	3	13	115	9	24	95	45	202.2	Non-brake
OMP10M252A2LC3									240.3	Holding brake

### (4) AC220V 130 flange motor

Model	LC(mm)	LE(mm)	LF(mm)	LA(mm)	LZ(mm)	S(mm)	LB(mm)	LR(mm)	LL(mm)	Brake/non-brake
23-bit optical encoder motor										
OMP13M851N2L2	130	4	13	145	9	22	110	55	145	Non-brake
OMP13M851A2L2									178	Holding brake
OMP13M132N2L2	130	4	13	145	9	22	110	55	160	Non-brake
OMP13M132A2L2									193	Holding brake
OMP13M102N2L2	130	4	14	145	9	22	110	55	171	Non-brake
OMP13M102A2L2									215	Holding brake
OMP13M152N2L2	130	4	14	145	9	22	110	55	186	Non-brake
OMP13M152A2L2									230	Holding brake
25-bit optical encoder motor										
OMP13M851N2L3	130	4	12	145	9	22	110	55	146.9	Non-brake
OMP13M851A2L3									167.4	Holding brake
OMP13M132N2L3	130	4	12	145	9	22	110	55	146.9	Non-brake
OMP13M132A2L3									167.4	Holding brake
OMP13M182N2L3	130	4	12	145	9	22	110	55	164.9	Non-brake
OMP13M182A2L3									185.4	Holding brake
OMP13M102N2L3	130	4	12	145	9	22	110	55	146.9	Non-brake
OMP13M102A2L3									167.4	Holding brake
OMP13M152N2L3	130	4	12	145	9	22	110	55	146.9	Non-brake
OMP13M152A2L3									167.4	Holding brake
OMP13M202N2L3	130	4	12	145	9	22	110	55	164.9	Non-brake
OMP13M202A2L3									185.4	Holding brake
OMP13M302N2L3	130	4	12	145	9	22	110	55	183.9	Non-brake
OMP13M302A2L3									204.4	Holding brake
OMP13H402N2L3	130	4	12	145	9	22	110	55	203.4	Non-brake
OMP13H402A2L3									223.9	Holding brake

(5) AC380V 100 flange motor

Model	LC(mm)	LE(mm)	LF(mm)	LA(mm)	LZ(mm)	S(mm)	LB(mm)	LR(mm)	LL(mm)	Brake/non-brake
25-bit optical encoder motor										
OMP10M102N4L3	100	3	13	115	9	24	95	45	142.2	Non-brake
OMP10M102A4L3									180.3	Holding brake
OMP10M152N4L3	100	3	13	115	9	24	95	45	142.2	Non-brake
OMP10M152A4L3									180.3	Holding brake
OMP10M202N4L3	100	3	13	115	9	24	95	45	162.2	Non-brake
OMP10M202A4L3									200.3	Holding brake
OMP10M252N4L3	100	3	13	115	9	24	95	45	202.2	Non-brake
OMP10M252A4L3									240.3	Holding brake

(6) AC380V 130 flange motor

Model	LC(mm)	LE(mm)	LF(mm)	LA(mm)	LZ(mm)	S(mm)	LB(mm)	LR(mm)	LL(mm)	Brake/non-brake
25-bit optical encoder motor										
OMP13H132N4L3	130	4	12	145	9	22	110	55	164.9	Non-brake
OMP13H132A4L3									185.4	Holding brake
OMP13H182N4L3	130	4	12	145	9	22	110	55	183.9	Non-brake
OMP13H182A4L3									204.4	Holding brake
OMP13M102N4L3	130	4	12	145	9	22	110	55	146.9	Non-brake
OMP13M102A4L3									167.4	Holding brake
OMP13M152N4L3	130	4	12	145	9	22	110	55	146.9	Non-brake
OMP13M152A4L3									167.4	Holding brake
OMP13M202N4L3	130	4	12	145	9	22	110	55	164.9	Non-brake
OMP13M202A4L3									185.4	Holding brake
OMP13M302N4L3	130	4	12	145	9	22	110	55	183.9	Non-brake
OMP13M302A4L3									204.4	Holding brake
OMP13H402N4L3	130	4	12	145	9	22	110	55	203.4	Non-brake
OMP13H402A4L3									223.9	Holding brake

(7) AC380V 180 flange motor

Model	LC(mm)	LE(mm)	LF(mm)	LA(mm)	LZ(mm)	S(mm)	LB(mm)	LR(mm)	LL(mm)	Brake/non-brake
25-bit optical encoder motor										
OMP18M292N4L3	180	3.2	23	200	13.5	35	114.3	79	174	Non-brake
OMP18M292A4L3									207.5	Holding brake
OMP18M452N4L3	180	3.2	23	200	13.5	35	114.3	79	196.5	Non-brake
OMP18M452A4L3									230	Holding brake
OMP18M552N4L3	180	3.2	23	200	13.5	42	114.3	113	225.5	Non-brake
OMP18M552A4L3									259	Holding brake
OMP18M752N4L3	180	3.2	23	200	13.5	42	114.3	113	262.5	Non-brake
OMP18M752A4L3									296	Holding brake

Naming rules for motor cables



OLE	Cable Application	
1-3	Symbol	Type
	OLE	Encoder line
	OLD	Power Line
	OLB	Brake cable

0	Wire diameter	
7	Symbol	Type
	0	0.2mm <sup>2</sup> /24AWG
	1	0.3mm <sup>2</sup> /22AWG
	A	0.5mm <sup>2</sup> /20AWG
	2	0.75mm <sup>2</sup> /18AWG
	3	1.5mm <sup>2</sup> /15AWG
	4	2.5mm <sup>2</sup> /13AWG
5	4mm <sup>2</sup> /11AWG	
6	6mm <sup>2</sup>	

A	Motor Encoding	
4	Symbol	Type
	A	OMP Series Motors

G	Cable specifications	
5	Symbol	Type
	S	Ordinary cable (2 million times)
	G	High-flex cable (5 million times)

5	Driver side terminal type	
8	Power line terminal	
	Symbol	Type
	1	Needle type + special shape
	2	Full needle type
	3	U-shaped + special-shaped
	Encoder line terminal	
	Symbol	Type
	5	6PIN 1394
	6	10PIN 1394
	A	14PIN high density terminal
	Brake wire terminal	
	Symbol	Type
	2	Full needle type
	4	U-Shape

B	Encoder type/Brake type	
6	Encoding type of encoder line	
	Symbol	Encoder Type
	D	Incremental encoder
	B	Absolute encoder (with battery box)
	Power line brake type	
	Symbol	Brake type
	B	With brake
	N	Without brake
	Power line brake type	
	Symbol	Brake type
	B	With brake

## Cable accessories

### 1. Motor power line

Driver Series	Motor Information	Whether to hold the brake	Cable Model	Remark	
Ω6-A Series Drivers	40/60/80 flange (drop line type)	Non-brake	OLD-A-SN21-xxx-1	The "xxx" mark in the cable model cable length, standard length as shown below: 030: 3m 050: 5m 100: 10m	
		Holding brake	OLD-A-SN21-xxx-1 OLB-A-SB22-xxx-1		
	40/60/80 flange (strip plug type)	Non-brake	OLD-A-SN21-xxx-H		
		Holding brake	OLD-A-SB21-xxx-H		
	100/130 flange, motor up to 2kW (Excluding 2kW)	Non-brake	OLD-A-SN31-xxx-5		
		Holding brake	OLD-A-SB31-xxx-9		
	100/130 flange, 2kW motor and above (including 2kW)	Non-brake	OLD-A-SN43-xxx-5		
		Holding brake	OLD-A-SB43-xxx-9		
	180 Flange	Non-brake	OLD-A-SN43-xxx-K		
		Holding brake	OLD-A-SN43-xxx-K OLB-A-SB22-xxx-5		
	Ω6-C Series Drivers	40/60/80 flange (drop line type)	Non-brake		OLD-A-SN22-xxx-1
			Holding brake		OLD-A-SN22-xxx-1 OLB-A-SB22-xxx-1
40/60/80 flange (strip plug type)		Non-brake	OLD-A-SN22-xxx-H		
		Holding brake	OLD-A-SB22-xxx-H		
130 Flange		Non-brake	OLD-A-SN31-xxx-5		
		Holding brake	OLD-A-SB31-xxx-9		
Ω6-W Series Drivers	40/60/80 flange (drop line type)	Non-brake	OLD-A-SN22-xxx-1		
		Holding brake	OLD-A-SN22-xxx-1 OLB-A-SB22-xxx-1		
	40/60/80 flange (strip plug type)	Non-brake	OLD-A-SN22-xxx-H		
		Holding brake	OLD-A-SB22-xxx-H		

### 2. Motor encoder cable

Driver Series	Motor flange size	Cable Model	Remark
Ω6-A Series Drivers	40/60/80 flange (drop line type)	OLE-A-S*05-xxx-1	The "*" in the cable model indicates incremental (D) or absolute Formula (B), no battery required The preferred increment of the box is recommended Formula D.
	40/60/80 flange (strip plug type)	OLE-A-S*05-xxx-8	
	100/130 flange	OLE-A-S*05-xxx-5	
	180 flange	OLE-A-S*05-xxx-5	
Ω6-C Series Drivers	40/60/80 flange (drop line type)	OLE-A-S*0A-xxx-1	
	40/60/80 flange (strip plug type)	OLE-A-S*0A-xxx-8	
	100/130 flange	OLE-A-S*0A-xxx-5	
Ω6-W Series Drivers	40/60/80 flange (drop line type)	OLE-A-S*0A-xxx-1	
	40/60/80 flange (strip plug type)	OLE-A-S*0A-xxx-8	

Note: 1. If there is no special requirement, ordinary flexible cables are preferred.

030	Cable length	
9-11	Symbol	Type
	030	3.0m
	050	5.0m
	100	10.0m

8	Motor side terminal type	
12	Power line terminal	
	Symbol	Type
	1	Palace grid (40/60/80 flange)
	5	Military specification 20-4 right angle (100/130 flange without brake)
	9	Military specification 20-18 right angle (100/130 flange with brake)
	H	Military specification square (40/60/80 flange)
	K	YD32K4 right angle type (180 flange without brake)
	Encoder line terminal	
	Symbol	Type
	1	Palace grid (40/60/80 flange)
	5	Military specification 20-29 right angle (100/130 flange)
	8	Military specification square (40/60/80 flange)
	E	YD28K7TS(1.5) (180 flange)
	Brake wire terminal	
	Symbol	Type
	1	Palace grid (40/60/80 flange)
	5	2PIN aviation plug straight type (WS16K2Z) (180 flange brake)

*	Special number	
13	Symbol	Type
	vacancy	Standard cables

Note: 1. Ordinary cables, power cables and encoder cables are black.

2. Highly flexible cables, power lines use orange color, encoder line adopts green